

# CONNECTOR SOLUTIONS TO MEET THE PRESCRIPTIVE LOADS OF 2006 IRC TABLE R404.1(1)

The 2006 edition of the *International Residential Code (IRC)* contains several new provisions regarding the connection between the top of a concrete or masonry foundation wall and the floor system. Specifically Table R404.1(1) of the 2006 *IRC* was added which specifies prescriptive support requirements based on calculated horizontal soil load reactions at the top of the wall. The magnitude of these reactions, and subsequent connector requirements, are functions of the foundation wall height, unbalanced backfill height, and soil type.

Based on the soil loads contained in Table R404.1(1), USP developed two new products to meet the requirements of the code. The products, the LJC-TZ and LJQ-TZ series, are designed to be more economical and install easier than the code prescribed connectors. They are also designed to satisfy the fastener spacing and end distance requirements of engineered wood floor joists. Many of the connectors listed in Table R404.1(1), as well as other connectors available, do not meet the I-Joist manufacturers requirements for this application.

## Soil Type

The soil pressure against a foundation wall varies depending on the soil type, height of the foundation wall, and backfill height. The two letter symbol representing the different soil classes on Table R404.1(1) are part of the Unified Soil Classification System (USCS) used to describe the texture and grain size of a soil. The first letter typically describes the type of soil and the second letter describes the soil properties.

The table below shows the descriptions for the different United Soil Classification System symbols given in the International Building Code. In the code each of these soil classification two letter symbols is assigned an active and passive pressure value which translates into the force the soil will impose on the foundation wall. Generally, well draining sand and gravelly soils will impose less force on a foundation wall compared to clayey type soils which don't drain as well. If there is uncertainty regarding the soil classification at a particular site, the building official or a qualified geotechnical engineer should be consulted.

First Letter Type of Soil Key	Unified Soil Classification	Description of Backfill Material
G = Gravel	GW	Well-graded, clean gravels; gravel-sand mixes
S = Sand	GP	Poorly graded, clean gravels; gravel-sand mixes
M = Silt	SW	Well-graded, clean sands; gravelly sand mixes
C = Clay	SP	Poorly graded, clean sands; sand-gravel mixes
O = Organic	GM	Silty gravels, poorly graded gravel-sand mixes
	GC	Clayey gravels, poorly graded gravel-and-clay mixes
	SM-SC	Sand-silt clay mix with plastic fines
	ML	Inorganic silts and clayey silts
	SC	Clayey sands, poorly graded sand-clay mixes
	MH	Inorganic clayey silts, elastic silts
	ML-CL	Mixture of inorganic silt and clay
	CL	Inorganic clays of low to medium plasticity

Second Letter Soil Properties Key
P = Poorly graded
W = Well graded
H = High plasticity
L = Low plasticity

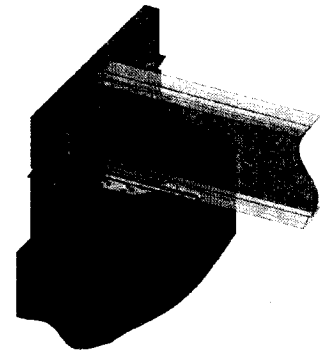

Typical LJC-TZ installation

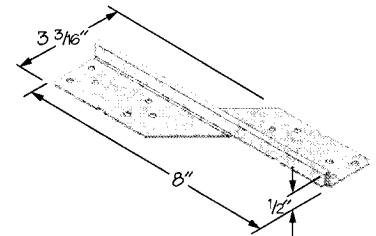

LJC-TZ

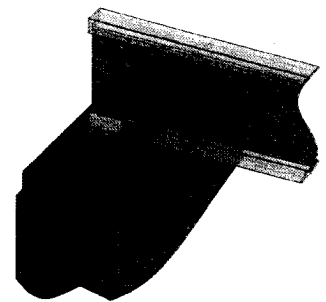

Typical LJQ-TZ installation

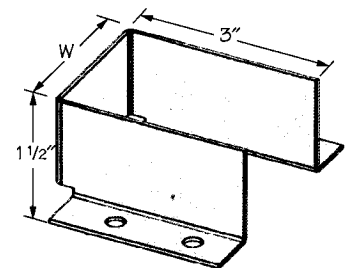

LJQ-TZ



A GIBRALTAR INDUSTRIES COMPANY

## LOAD PATH

An objective of the new language in Section R404.1 is to ensure there is a continuous load path to transfer unbalanced soil loads through the structure to the foundation. Most foundation walls are designed to span vertically from the wall footing to the first floor diaphragm. When lateral soils are imposed on a foundation wall, a portion of the load is transferred down to the footing and the other part is transferred up to the floor diaphragm. If the foundation walls on all sides of the structure have the same depth and backfill height on all four sides of the basement, lateral support at the top of the wall is achieved by providing a continuous load path to the opposite wall and the sidewalls.

If the soil loads are not balanced, as with many walkout and daylight basements, a continuous load path is required to transfer soil loads through the floor diaphragm to the side foundation walls. To transfer the loads, the floor diaphragm behaves like a beam loaded from the unbalanced soil foundation wall and spans to the side foundation walls. Figure 1 below graphically shows the load path of the lateral soil load in an unbalanced soil condition.

Section R404.1 contains connection requirements to ensure the intended load path is capable of transferring the required lateral soil load. Table R404.1(1) provides the lateral load reaction at the top to the wall as well as prescriptive connections to transfer the load. The section also requires a 20 gage metal clip with (5) 8d x 1-1/2" nails at 24-inch on center, or an approved connector capable of transferring 230 pounds per linear foot, to be used to connect the rim board to the sill plate. This connection, shown in Figure 2, is needed to transfer soil loads from the floor diaphragm to the side foundation wall. The USP MPA1 is capable of transferring this load and can be spaced at 24 inches on center.

Revised versions of Table R404.1(1) providing economical connections to meet the code requirements are shown on page 3 for I-Joist Floor Systems and on page 4 for Dimension Lumber Floor Systems. Each table includes different connection options including toe nails, the LJC-TZ and the Ljq-TZ which have varying capacities. Please note the connectors called out prescriptively in the code may not work for all I-Joist floor systems. The LJC-TZ, however, has been specifically designed to accommodate the fastener spacing and end distance requirements of I-Joist manufacturers. For additional information please contact USP or the specific I-Joist manufacturer.

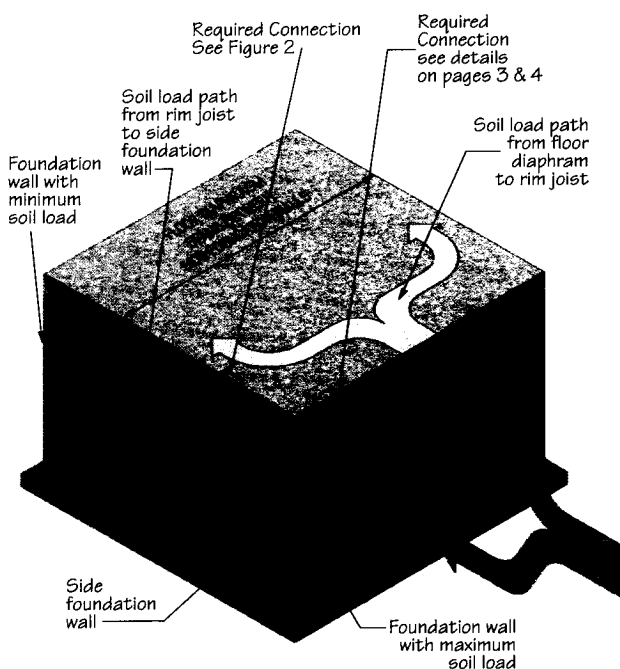

**FIGURE 1**  
**Unbalanced Soil**  
**Load Path**

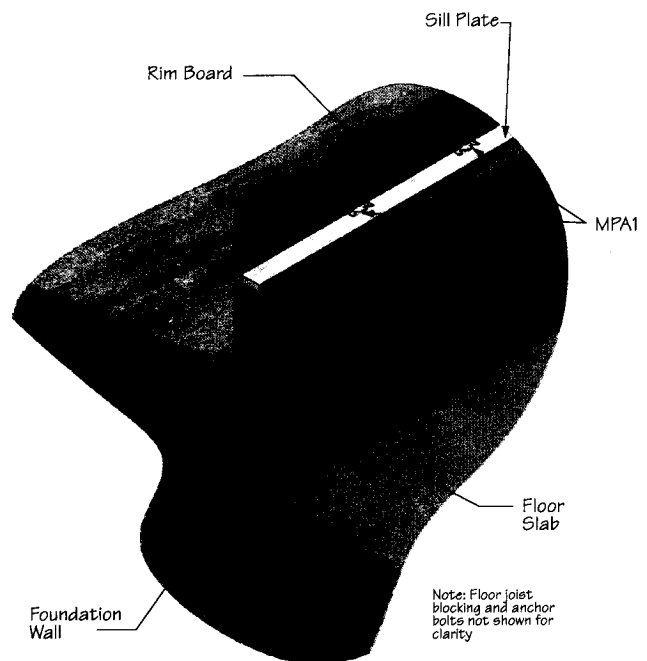

**FIGURE 2**  
**Side Foundation**  
**Wall Connections**

# I-JOIST FLOOR SYSTEMS

Maximum Wall Height (feet)	Maximum Unbalanced Backfill Height (feet)	Joist Spacing (inches)	Soil Classes (Letter indicates connection types)			
			GW GP SW and SP soils	GM, GC, SM, SC and ML soils	SC, MH, ML, CL and inorganic CL soils	
7	4	12	(2) 8d box nails	(2) 8d box nails	(2) 8d box nails	
		16	(2) 8d box nails	(2) 8d box nails	(2) 8d box nails	
		19.2	(2) 8d box nails	(2) 8d box nails	LJC-TZ	
		24	(2) 8d box nails	(2) 8d box nails	LJC-TZ	
	5	12	(2) 8d box nails	(2) 8d box nails	LJC-TZ	
		16	(2) 8d box nails	LJC-TZ	LJC-TZ	
		19.2	(2) 8d box nails	LJC-TZ	LJC-TZ	
		24	LJC-TZ	LJC-TZ	LJC-TZ	
	6	12	LJC-TZ	LJC-TZ	LJC-TZ	
		16	LJC-TZ	LJC-TZ	LJC-TZ	
		19.2	LJC-TZ	LJC-TZ	LJC-TZ	
		24	LJC-TZ	LJC-TZ	LJC-TZ	
7	12	LJC-TZ	LJC-TZ	LJC-TZ		
	16	LJC-TZ	LJC-TZ	LJC-TZ		
	19.2	LJC-TZ	LJC-TZ	LJC-TZ		
	24	LJC-TZ	LJC-TZ	LJC-TZ		
8	4	12	(2) 8d box nails	(2) 8d box nails	(2) 8d box nails	
		16	(2) 8d box nails	(2) 8d box nails	(2) 8d box nails	
		19.2	(2) 8d box nails	(2) 8d box nails	(2) 8d box nails	
		24	(2) 8d box nails	(2) 8d box nails	LJC-TZ	
	5	12	(2) 8d box nails	(2) 8d box nails	LJC-TZ	
		16	(2) 8d box nails	LJC-TZ	LJC-TZ	
		19.2	(2) 8d box nails	LJC-TZ	LJC-TZ	
		24	LJC-TZ	LJC-TZ	LJC-TZ	
	6	12	(2) 8d box nails	LJC-TZ	LJC-TZ	
		16	LJC-TZ	LJC-TZ	LJC-TZ	
		19.2	LJC-TZ	LJC-TZ	LJC-TZ	
		24	LJC-TZ	LJC-TZ	LJC-TZ	
	7	12	LJC-TZ	LJC-TZ	LJC-TZ	
		16	LJC-TZ	LJC-TZ	LJC-TZ	
		19.2	LJC-TZ	LJC-TZ	LJC-TZ	
		24	LJC-TZ	LJC-TZ	LJC-TZ	
	8	12	LJC-TZ	LJC-TZ	LJC-TZ	
		16	LJC-TZ	LJC-TZ	LJC-TZ	
		19.2	LJC-TZ	LJC-TZ	LJC-TZ	
		24	LJC-TZ	LJC-TZ	LJC-TZ	
	9	4	12	(2) 8d box nails	(2) 8d box nails	(2) 8d box nails
			16	(2) 8d box nails	(2) 8d box nails	(2) 8d box nails
			19.2	(2) 8d box nails	(2) 8d box nails	(2) 8d box nails
			24	(2) 8d box nails	(2) 8d box nails	(2) 8d box nails
5		12	(2) 8d box nails	(2) 8d box nails	LJC-TZ	
		16	(2) 8d box nails	LJC-TZ	LJC-TZ	
		19.2	(2) 8d box nails	LJC-TZ	LJC-TZ	
		24	(2) 8d box nails	LJC-TZ	LJC-TZ	
6		12	(2) 8d box nails	LJC-TZ	LJC-TZ	
		16	LJC-TZ	LJC-TZ	LJC-TZ	
		19.2	LJC-TZ	LJC-TZ	LJC-TZ	
		24	LJC-TZ	LJC-TZ	LJC-TZ	
7		12	LJC-TZ	LJC-TZ	LJC-TZ	
		16	LJC-TZ	LJC-TZ	LJC-TZ	
		19.2	LJC-TZ	LJC-TZ	LJC-TZ	
		24	LJC-TZ	LJC-TZ	LJC-TZ	
8		12	LJC-TZ	LJC-TZ	LJC-TZ	
		16	LJC-TZ	LJC-TZ	LJC-TZ	
		19.2	LJC-TZ	LJC-TZ	LJC-TZ	
		24	LJC-TZ	LJC-TZ	LJC-TZ	
9		12	LJC-TZ	LJC-TZ	LJC-TZ	
		16	LJC-TZ	LJC-TZ	LJC-TZ	
		19.2	LJC-TZ	LJC-TZ	LJC-TZ	
		24	LJC-TZ	LJC-TZ	LJC-TZ	

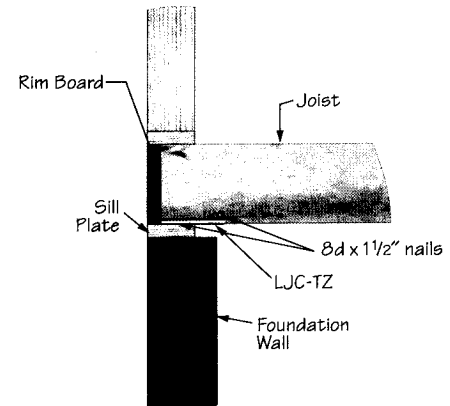

**Typical LJC-TZ front view installation**

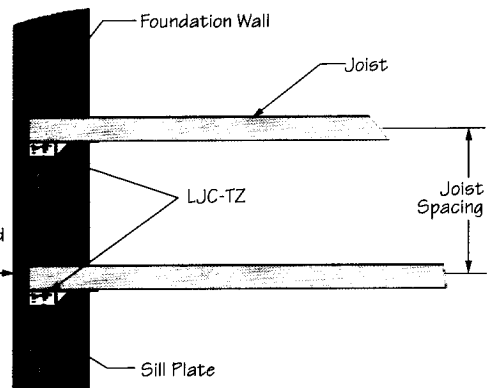
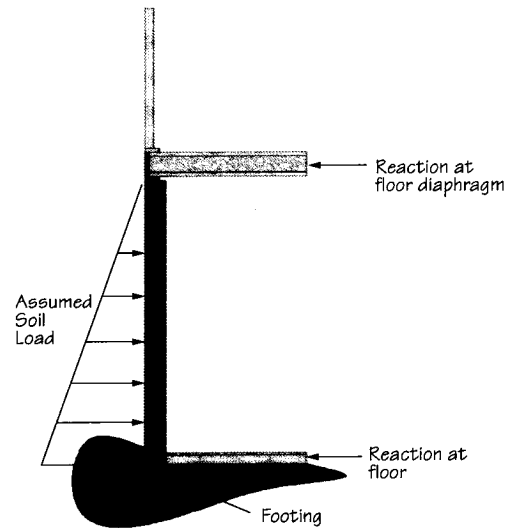

**Typical LJC-TZ expanded plan view installation**

**Connection capacity per foot of wall**

Spacing	(2) 8d box I-Joist	LJC-TZ I-Joist	LJC-TZ
12	142	513	1143
16	107	385	857
19.2	89	321	714
24	71	257	572

**I-Joist Floor Systems Chart**

**GENERAL NOTES:**

1. Table uses the following values for the connections: (2) 8d box nails = 142 lbs.; LJC-TZ = 515 lbs.; LJC-TZ = 1145 lbs.
2. A load duration factor of 0.9 has been used to determine the allowable loads.
3. Calculations based on 2 x 6 SP sill plate. For 2x4 sill plate applications reduce the value of the LJC-TZ by 45 percent.
4. Table assumes a two inch minimum end distance requirement for the I-joist.

# DIMENSIONAL LUMBER FLOOR SYSTEMS

Maximum Wall Height (feet)	Maximum Unbalanced Backfill Height (feet)	Joist Spacing (inches)	Soil Classes (Letter indicates connection types)		
			GW GP SIV and SP soils	GM G.O. SIF-SC and ML soils	SC MH ML-CL and inorganic CL soils
7	4	12	toe nail w/ (3) 8d box	toe nail w/ (3) 8d box	toe nail w/ (3) 8d box
		16	toe nail w/ (3) 8d box	toe nail w/ (3) 8d box	toe nail w/ (3) 8d box
		19.2	toe nail w/ (3) 8d box	toe nail w/ (3) 8d box	LJC-TZ
		24	toe nail w/ (3) 8d box	toe nail w/ (3) 8d box	LJC-TZ
	5	12	toe nail w/ (3) 8d box	toe nail w/ (3) 8d box	LJC-TZ
		16	toe nail w/ (3) 8d box	LJC-TZ	LJC-TZ
		19.2	LJC-TZ	LJC-TZ	LJC-TZ
		24	LJC-TZ	LJC-TZ	LJC-TZ
	6	12	LJC-TZ	LJC-TZ	LJC-TZ
		16	LJC-TZ	LJC-TZ	LJC-TZ
		19.2	LJC-TZ	LJC-TZ	LJC-TZ
		24	LJC-TZ	LJC-TZ	LJC-TZ
7	12	LJC-TZ	LJC-TZ	LJC-TZ	
	16	LJC-TZ	LJC-TZ	LJC-TZ	
	19.2	LJC-TZ	LJC-TZ	LJC-TZ	
	24	LJC-TZ	LJC-TZ	LJC-TZ	
8	4	12	toe nail w/ (3) 8d box	toe nail w/ (3) 8d box	toe nail w/ (3) 8d box
		16	toe nail w/ (3) 8d box	toe nail w/ (3) 8d box	toe nail w/ (3) 8d box
		19.2	toe nail w/ (3) 8d box	toe nail w/ (3) 8d box	toe nail w/ (3) 8d box
		24	toe nail w/ (3) 8d box	toe nail w/ (3) 8d box	LJC-TZ
	5	12	toe nail w/ (3) 8d box	toe nail w/ (3) 8d box	LJC-TZ
		16	toe nail w/ (3) 8d box	LJC-TZ	LJC-TZ
		19.2	toe nail w/ (3) 8d box	LJC-TZ	LJC-TZ
		24	LJC-TZ	LJC-TZ	LJC-TZ
	6	12	toe nail w/ (3) 8d box	LJC-TZ	LJC-TZ
		16	LJC-TZ	LJC-TZ	LJC-TZ
		19.2	LJC-TZ	LJC-TZ	LJC-TZ
		24	LJC-TZ	LJC-TZ	LJC-TZ
7	12	LJC-TZ	LJC-TZ	LJC-TZ	
	16	LJC-TZ	LJC-TZ	LJC-TZ	
	19.2	LJC-TZ	LJC-TZ	LJC-TZ	
	24	LJC-TZ	LJC-TZ	LJC-TZ	
8	12	LJC-TZ	LJC-TZ	LJC-TZ	
	16	LJC-TZ	LJC-TZ	LJC-TZ	
	19.2	LJC-TZ	LJC-TZ	LJC-TZ	
	24	LJC-TZ	LJC-TZ	LJC-TZ	
9	4	12	toe nail w/ (3) 8d box	toe nail w/ (3) 8d box	toe nail w/ (3) 8d box
		16	toe nail w/ (3) 8d box	toe nail w/ (3) 8d box	toe nail w/ (3) 8d box
		19.2	toe nail w/ (3) 8d box	toe nail w/ (3) 8d box	toe nail w/ (3) 8d box
		24	toe nail w/ (3) 8d box	toe nail w/ (3) 8d box	toe nail w/ (3) 8d box
	5	12	toe nail w/ (3) 8d box	toe nail w/ (3) 8d box	toe nail w/ (3) 8d box
		16	toe nail w/ (3) 8d box	toe nail w/ (3) 8d box	LJC-TZ
		19.2	toe nail w/ (3) 8d box	LJC-TZ	LJC-TZ
		24	toe nail w/ (3) 8d box	LJC-TZ	LJC-TZ
	6	12	toe nail w/ (3) 8d box	LJC-TZ	LJC-TZ
		16	LJC-TZ	LJC-TZ	LJC-TZ
		19.2	LJC-TZ	LJC-TZ	LJC-TZ
		24	LJC-TZ	LJC-TZ	LJC-TZ
7	12	LJC-TZ	LJC-TZ	LJC-TZ	
	16	LJC-TZ	LJC-TZ	LJC-TZ	
	19.2	LJC-TZ	LJC-TZ	LJC-TZ	
	24	LJC-TZ	LJC-TZ	LJC-TZ	
8	12	LJC-TZ	LJC-TZ	LJC-TZ	
	16	LJC-TZ	LJC-TZ	LJC-TZ	
	19.2	LJC-TZ	LJC-TZ	LJC-TZ	
	24	LJC-TZ	LJC-TZ	LJC-TZ	
9	12	LJC-TZ	LJC-TZ	LJC-TZ	
	16	LJC-TZ	LJC-TZ	LJC-TZ	
	19.2	LJC-TZ	LJC-TZ	LJC-TZ	
	24	LJC-TZ	LJC-TZ	LJC-TZ	

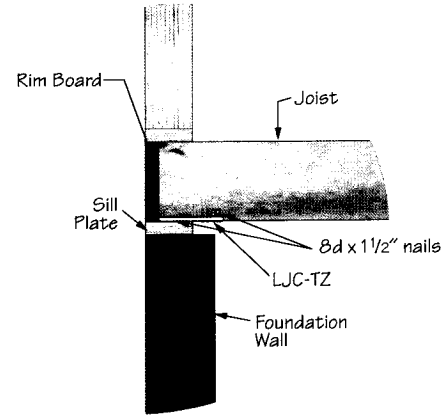

Typical LJC-TZ front view installation

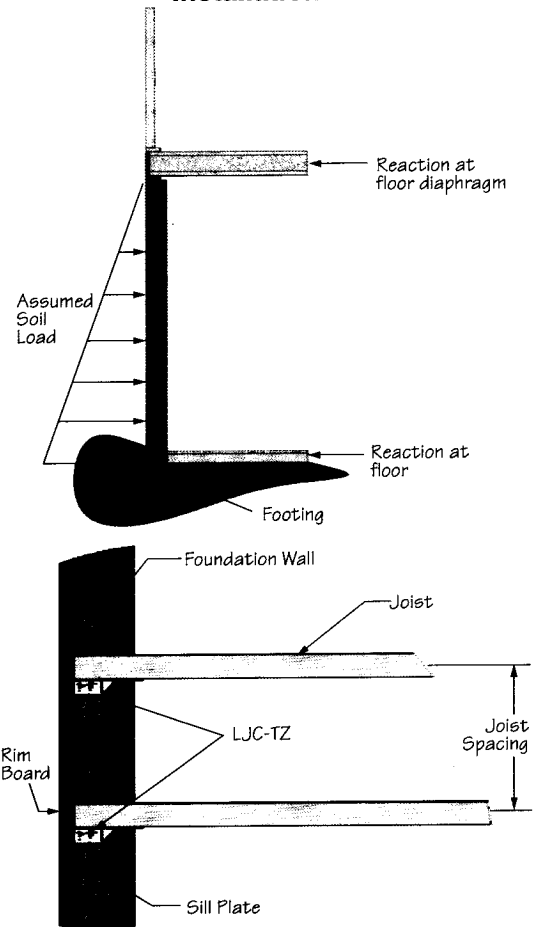

Typical LJC-TZ expanded plan view installation

**Dimensional Lumber Floor Systems Chart**

**GENERAL NOTES:**

1. Table uses the following values for the connections: (3) 8d box nails = 137 lbs.; LJC-TZ = 443 lbs.; LJQ-TZ = 905 lbs.
2. A load duration factor of 0.9 has been used to determine the allowable loads.
3. 3 - 8d box nails are per 2006 IRC Table 602.3(1)
4. Lateral design values for (3) 8d box nails have been multiplied by a toe nail factor of 0.83 (NDS 11.5.4.2)
5. Calculations based on 2 x 6 SP sill plate. For 2x4 sill plate applications reduce the value of the LJC-TZ by 45 percent.
6. Table assumes the 2x floor joist is SPF material.

**Connection capacity per foot of wall**

Spacing	(3) 8d box Toe Nail	LJC-TZ 2x	LJQ-TZ
12	137	443	1143
16	103	332	857
19.2	86	277	714
24	69	222	572

**Customer Service:**  
Burnsville, MN  
Phone: 1-800-328-5934  
Fax: 1-507-364-8762

**Manufacturing:**  
Montgomery, MN • Livermore, CA  
Largo, FL • Rancho Cucamonga, CA  
Thornhill, Ontario

**Warehouses:**  
Houston, TX  
Lumberton, NJ