

Vinyl Siding

CITY OF Owatonna

BUILDING DEPARTMENT

507- 444-4370

www.ci.owatonna.mn.us

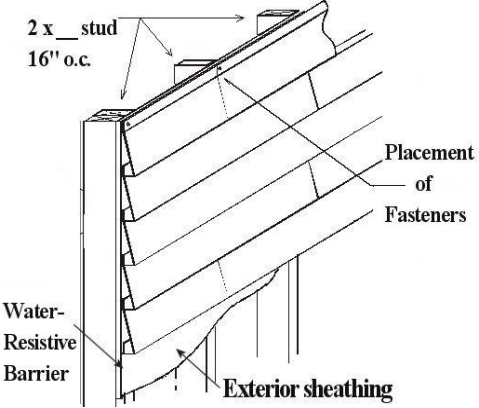

2 x stud
16" o.c.

Placement of Fasteners

Water-Resistive Barrier

Exterior sheathing

This handout is intended only as a guide and is based in part on the 2007 Minnesota State Building Code, the 2007 Minnesota State Fire code and the City of Owatonna ordinances, and good building practice. While every attempt has been made to insure the correctness of this handout, no guarantees are made to its accuracy or completeness. Responsibility for compliance with applicable codes and ordinances falls on the owner or contractor. For specific questions regarding code requirements, refer to the applicable codes or contact your local Building Department.

The information in this handout applies to most re-siding installations for residential construction. If there is a conflict between these requirements and the siding manufacturer's, the siding manufacturer's installation instructions shall be followed. A copy of the manufacturer's installation instructions should be provided with the application for the building permit or shall be available at time of inspection.

PERMITS

A building permit is required for all residing of residential dwellings and for all accessory structures over 120 square feet in sizes.

SUBMITTALS REQUIRED TO OBTAIN A BUILDING PERMIT

- A completed building permit application for residing work showing the type of siding to be used including the product, brand, manufacturer and profile.
- A complete evaluation service report and manufacturer's specifications. (See reference site) <http://www.icc-es.org/reports/index.cfm?search=search>

INSTALLATION

- Vinyl siding shall be installed in accordance to its manufacturer's installation instruction. Vinyl siding has a web site that will illustrate how their product shall be installed. All vinyl siding shall be properly labeled and tested according to ASTM D3679. www.vinylsiding.org or <http://www.vinylsiding.org/aboutsiding/installation/manual/index.asp>
- Where siding is installed horizontally, the fastener spacing shall not exceed the stud spacing horizontally and 12 inches vertically.
- All siding and residing installations require compliant flashing by the code (R703.8) and by the manual of Vinyl Siding Institute installation instruction and weather resistive sheathing paper (R703.2.)



INSPECTIONS

- A final inspection is required.
- It is the permit holder's responsibility to call for all required inspections.

ON SITE INFORMATION

- The manufacturers complete installation instructions must be on site at all times. If instructions are not provided, the installation must meet the requirements of the Vinyl Siding Institute.
- Each siding carton should be labeled indicating compliance with standard ASTM D3679. If the product is not labeled then a stop work order will be issued until verification has been confirmed that the product meet all ASTM D3679 standards and VSI requirements.

EXTERIOR COVERING INSPECTIONS APPLY TO THE FOLLOWING

- All new construction, residential and commercial.
- Any additions.
- Any re-siding projects where the existing exterior covering is being removed or covered.

Note: Water resistive barriers are not required for detached accessory buildings according to the code languages but may be required by vinyl siding manufacturer's installation requirements. (Water resistive barrier, commonly known as housewrap) ***

Building and Inspection will not accept pictures as a substitute for an inspection.

IMPORTANT CONSIDERATIONS

- Your permit card with the manufacturer's installation instructions must be on site for the housewrap, vinyl siding and final inspection.
- If you change the product that was approved by the City for your permit, you must have the installation instructions at the job site.
- One-story houses will have one housewrap and a final inspection.
- Two-story houses, where scaffolding or other equipment must be set up, could potentially have a number of inspections. (At a minimum one side must be completely installed before an inspection.)
- Flashing/weather-protection shall be installed around all openings. Other members requiring flashing/weather-protection include trim and deck ledgers. All flashing must be in place for the housewrap inspection.
- You may not deviate from the manufacturer's installation instructions. The condition of the wall sheathing shall be checked after removal of the old siding. Damaged sheathing shall be replaced. The extent of the damage will determine if other items (e.g. - insulation, studs) will need to be replaced or repaired.
- Any rips, tears or holes in the house wrap must be repaired per the instructions and be done by time of inspection.
- An electrical permit is required if removing meter sockets, air conditioner shut-offs or similar electrical devices. **Contact:** State Electrical Inspector, Mike Anthony at 507.465.3522.
- Each house has a wire running from the water meter inside the house to the outside reader. When the house siding is replaced, all necessary precautions must be taken to avoid damage to this wire. If damage to the wire does occur, the contractor will be responsible for its complete replacement from the water meter to the outside register.
- Water meter remote devices will be remounted by the Owatonna Public Utilities after re-siding. There is no charge for this service. Call 507.451.1616 to request the remount.

Additional contacts:

Call Owatonna Public Utilities at 507.451.1616 to ask for help when loosening any exterior electrical meter, heads or wires. On most cases there will not be any service fees or charges. Please caution to the safety side.

Rough-In Inspection: A Rough-In Inspection should be scheduled when the work begins. This inspection will be done as time allows. Do not cover the entire project until the Rough-In inspection is approved.

Exterior Openings Flashing: All exterior openings shall be flashed. (See illustration down below)

Window Flanges and Flashings: Typically, felt or approved wrap is installed on the bottom and the sides of the window, covering the framing members to at least the dimension of the jamb depth, and extending outside and over wall sheathing before installing the window. Felt or approved wrap on the top of the window shall go over the window flashing. If a window is in place, and not being replaced, a layer of approved flashing material is installed over the bottom, side and top window flanges to make them weatherproof. Apply sealants as necessary to protect the structure. *Building code requires a drip cap above all openings.*

Final Inspection: Schedule the Final Inspection after all work is complete including siding, soffit, fascia and all caulking. House numbers shall also be reinstalled before this inspection. If any electrical fixtures were removed, replaced or installed, the State Electrical Inspector shall approve the final electrical inspection.

Failure to call for the required inspection(s): Will require a minimum 8-foot by 8-foot section of siding to be removed. The building inspector will determine the area. If within that area the manufacturer's installation instructions have not been followed, all siding shall be removed and the water barrier corrected and re-inspected.

EXTERIOR COVERING

Exterior walls shall provide the building with a weather resistant exterior wall envelope. The exterior wall envelope shall include flashing as described in Section R703.8. The exterior wall envelope shall be designed and constructed in such a manner as to prevent the accumulation of water within the wall assembly by providing a water resistive barrier behind the exterior veneer as required.

WATER-RESISTIVE BARRIER

One layer of No. 15 asphalt felt, free from holes and breaks, complying with ASTM D 226 for Type 1 felt or other approved water-resistive barrier shall be applied over studs or sheathing of all exterior walls. Such felt or material shall be applied horizontally, with the upper layer lapped over the lower layer not less than 2 inches. Where vertical joints occur, felt shall be lapped not less than 6 inches. The felt or other approved material shall be continuous to the top of walls and terminated and/or sealed at penetrations and building appendages in a manner to meet the requirements of the exterior wall envelope as described.

Exception: Omission of the water-resistive barrier is permitted in the following situations.

1. In detached accessory buildings.
2. Where specifically prohibited by a sheathing and/or siding manufacturer.

House Wrap: Beginning 3/31/03 the MN State Building Code required that a weather-resistive sheathing paper be installed under the siding. This provision applies to walls of heated and unheated spaces, and includes the gable ends adjacent to attic spaces. On re-siding jobs where the soffits are removed the paper shall extend into the soffit area. FAN-FOLD EXTERIOR BACKER PRODUCTS MAY NOT MEET THE CODE REQUIREMENT AS A WEATHER-RESISTIVE BARRIER. PRODUCTS MUST MEET ICC TESTING REQUIREMENT AC 71. (See reference site) http://www.icc-es.org/criteria/pdf_files/ac71.pdf

BASIC INSTALLATION RULES

By: Vinyl Siding Instituted (VSI)

Before getting started, it is important to review several rules of thumb for vinyl siding application. The following rules, which come up throughout this guide, are critical for proper vinyl siding installation:

1. Installed panels must move freely from side to side.
2. When installing a siding panel, push up from the bottom until the lock is fully engaged with the piece below it. Without stretching the panel, reach up and fasten it into place.
3. Fasten nails or other fasteners in the center of the nailing slot.
4. Do not force the panels up or down when fastening in position.
5. Do not drive the head of the fastener tightly against the siding nail hem. Allow 1/32" (about the thickness of a dime) clearance between the fastener head and the siding panel. Drive fasteners straight and level to prevent distortion and buckling of the panel.
6. Leave a minimum of 1/4" clearance at all openings and stops to allow for normal expansion and contraction. When installing in temperatures below 40° F, increase minimum clearance to 3/8".
7. Do not caulk the panels where they meet the receiver of inside corners, outside corners, or J-trim. Do not caulk the overlap joints.
8. Do not face-nail or staple through siding. Vinyl siding expands and contracts with outside temperature changes. Face-nailing can result in ripples in the siding.
9. In residing, furring or removal of uneven original siding may be necessary.
10. In new construction, avoid the use of green lumber as the underlayment. Keep in mind that siding can only be as straight and stable as what lies under it.
11. The installation of specific products may differ in details from the instructions given in this manual. Always follow the manufacturer's instructions, using parts specified by the manufacturer, to ensure proper installation.

FASTENING CHOICES - by: Vinyl Siding Instituted (VSI)

Use aluminum, galvanized steel, or other corrosion-resistant nails, staples, or screws when installing vinyl siding. Aluminum trim pieces require aluminum or stainless steel fasteners. All fasteners must be able to penetrate a minimum of 3/4" into framing or furring (*Fig. 1*). (Review your local building codes for variations that may apply to specific geographic areas.)

NAILS

Nail heads should be 5/16" minimum in diameter. Shank should be 1/8" in diameter (*Fig. 1*).

SCREWS FASTENERS

Screw fasteners can be used if the screws do not restrict the normal expansion and contraction movement of the vinyl siding panel on the wall. Screws must be centered in the slot with approximately 1/32" space between the screw head and the vinyl. Screws must be able to penetrate not less than 3/4" into framing or furring and should be:

- Size #8, truss head or pan head
- Corrosion-resistant, self-tapping sheet metal type

(*Fig. 1*)

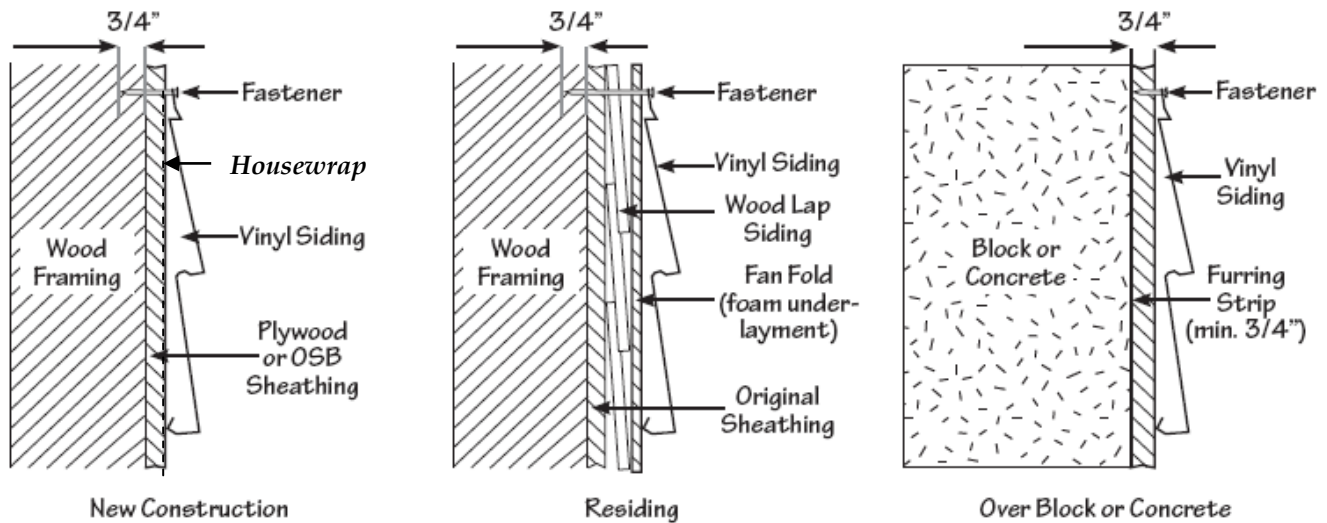
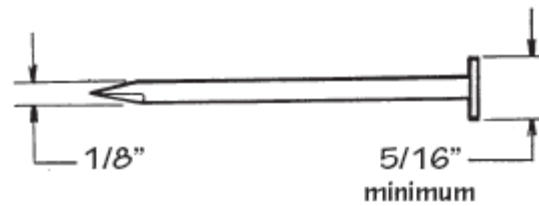

FASTENING PROCEDURE

Vinyl siding can expand and contract 1/2" or more over a 12' 6" length with changes in temperature. Whether using a nail, screw, or staple to fasten the siding, the following basic rules must be followed:

- Make sure the panels are fully locked along the length of the bottom, but do not force them up tight when fastening.
- Do not drive the head of the fastener tightly against the siding nail hem. Allow approximately 1/32" clearance

(*Fig. 2*)

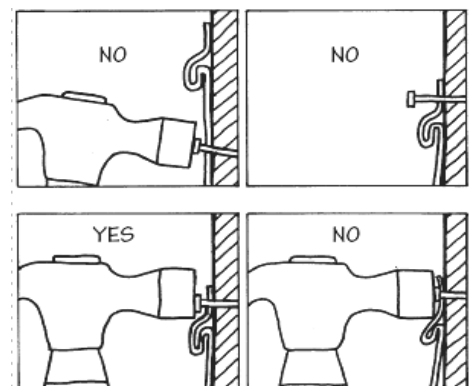

(the thickness of a dime) between the fastener head and the vinyl.

Tight nailing, screwing, or stapling will cause the vinyl siding to buckle with changes in temperature (Fig. 2).

- When fastening, start in the center of the panel and work toward the ends.
- Center the fasteners in the slots to permit expansion and contraction of the siding (Fig. 3).
- Drive fasteners straight and level to prevent distortion and buckling of the panel (Fig. 4).
- Space the fasteners a maximum of 16" apart for the horizontal siding panels, every 12" for the vertical siding panels, and every 8" to 12" for the accessories. These distances may be increased if the manufacturer permits greater spacing based on wind load testing. Start fastening vertical siding and corner posts in the top of the uppermost slots to hold them in position. Place all other fasteners in the center of the slots (Fig. 5).
- If a nail slot does not allow centering/securing into a nailable surface, use a nail hole slot punch to extend the slot and allow centering of the fastener.

Staples

If staples are being used instead of nails or screws, they must (Fig. 6):

- Not be less than 16-gauge semi-flattened to an elliptical cross-section.
- Penetrate not less than 3/4" (19mm) into framing or furring.
- Be wide enough in the crown to allow free movement of the siding (approximately 1/32" away from the nailing hem).

(Fig. 3)

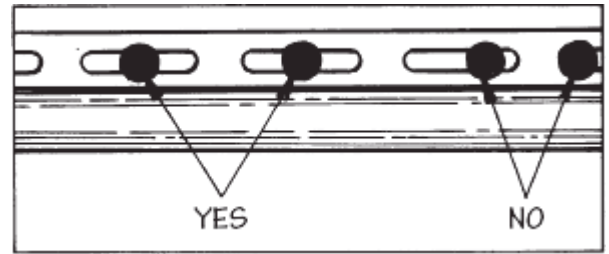

(Fig. 4)

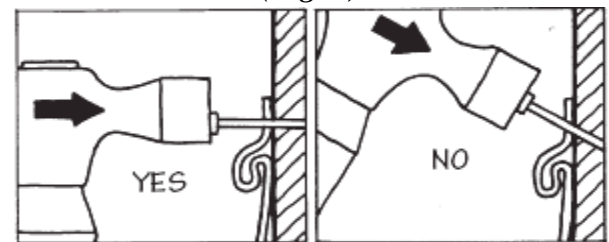

(Fig. 5)



(Fig. 6)

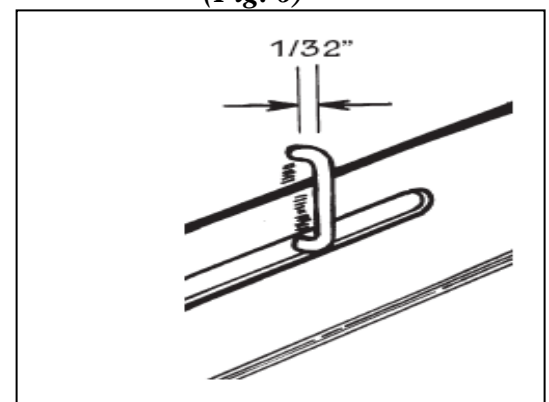

Kick-out Flashing

Minnesota Rule “Where the lower portion of a sloped roof stops within the plane of an intersecting wall, kick out flashing shall be installed to divert or water away from the assembly.”

