



Roofing

City of

Owatonna

BUILDING DEPARTMENT

507- 444-4370

www.ci.owatonna.mn.us

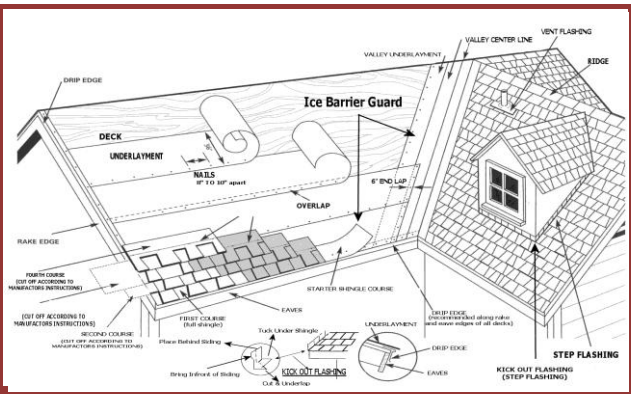

This handout is intended only as a guide and is based in part on the 2007 Minnesota State Building Code, City of Owatonna ordinances, and good building practice. While every attempt has been made to insure the correctness of this handout, no guarantees are made to its accuracy or completeness. Responsibility for compliance with applicable codes and ordinances falls on the owner or contractor. For specific questions regarding code requirements, refer to the applicable codes or contact your local Building Department.

SCOPE

The scope of this handout will be limited to the installation of two types of roofing materials.

- Asphalt Shingles
- Mineral-surfaced Roll Roofing

PERMITS, INSPECTIONS, AND LICENSES

Building permits are required for all roofing projects, (except commercial membrane roofs). Permits can be obtained from the City of Owatonna, 540 West Hills Circle, Owatonna MN 55060. Permits are issued at the time of application.

The Building Department requires two inspections: a per-permit or underlayment/decking and final inspection. If reroof project accurse over the weekend then a per-inspection is required with the applicator along with providing pictures of roof sheathing and underlayment placement with a shingle wrapper shall be submitted at final inspection.

All contractors engaged in roofing work must have a state contractor's license and show proof of the license to obtain a permit. Homeowners doing roofing shall be required to sign acknowledgment of code and licensing wavier. Specific questions regarding contractor licenses should be directed to the Minnesota Department of Commerce, 1-800-657-3978, web site: <https://secure.doli.state.mn.us/licensing/licensing.aspx>.

GENERAL

Roof coverings shall be applied in accordance with the applicable provisions of the codes section and the **manufacturer's installation instructions**. (R905.1)

All roof covering materials must be delivered in packages bearing the manufacturers identifying marks and approved testing agency labels when required.

All asphalt shingles must be either self-sealing or interlocking. (R905.2.4)

Roof decks must be solidly sheathed for asphalt shingles or mineral-surfaced roll roofing. Solid sheathing may be plywood, OSB, or 1-inch nominal boards. Roof decks that are rotted or unsound must be repaired prior to reroofing. (**Refer to manufacture's installation instructions** for the spacing requirements between boards and nominal board width).

Flashing is required at all wall and roof intersections, wherever there is a change in roof slope or direction, and around roof openings. When flashing is metal, it must be corrosion resistant metal with a thickness of not less than 0.019 inch (No. 26 galvanized sheet) (R903.2.).

Sidewall flashing (26-Gauge)



ICE AND WATER BARRIERS

An ice and water barrier is required on all roofs except for detached accessory buildings. **Exception:** Detached accessory structures that contain conditioned floor area will require ice and water barrier. The barrier may be at least two layers of underlayment cemented together or a self-adhering polymer modified bitumen sheet. There are several manufacturers who make materials specifically for this requirement that are marketed under differing trade names. The ice and water barrier must extend from the edge of the eaves to a point **24 inches** inside the exterior wall line of the building. Ice and water barriers are not required along the rakes or in valleys (R905.2.7.1) (**except when required by manufacture installation instructions**).

REQUIRED LOCATION FOR ICE AND WATER BARRIERS

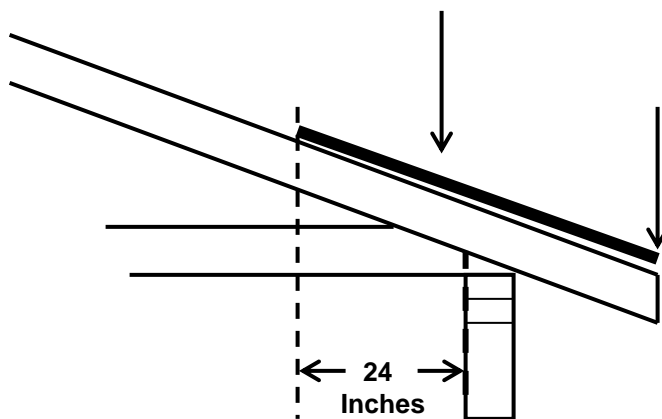

VENTILATION

Ventilation of enclosed attics and enclosed rafter spaces is required. Ventilation openings must be provided with corrosion-resistant mesh with openings of $\frac{1}{8}$ " to $\frac{1}{4}$ " inch. (R806.1)

Roofs having at least 50% but not more than 80% of the ventilating area provided by ventilators located in the upper portion of the space to be ventilated and at least 3 feet above the eave vents and the balance of the ventilation provided in the eave vents, ventilation may be 1 square foot of net free ventilating area for each 300 square feet of attic area. (R806.2)

Box vent



Gable vent



Ridge vent

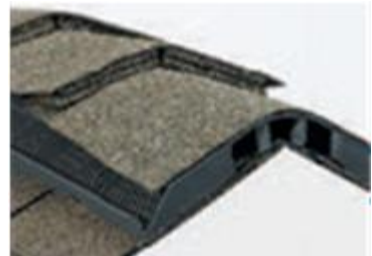

Fasteners for asphalt shingles shall be galvanized steel, stainless steel, aluminum or copper roofing nails, minimum 12 gage shank with a minimum $\frac{3}{8}$ -inch diameter head, of a length to penetrate through the roofing materials and a minimum of $\frac{3}{4}$ inch into the roof sheathing. Where the roof sheathing is less than $\frac{3}{4}$ inch thick, the fasteners shall penetrate through the sheathing. (R905.2.5)

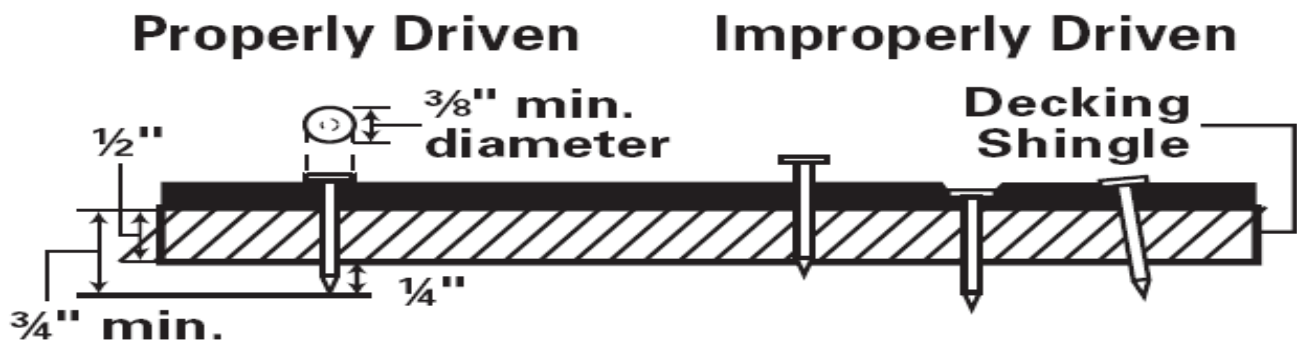

ASPHALT SHINGLES - R905.2

Asphalt shingles may only be used on roof slopes of two units vertical in 12 units horizontal (2:12) or greater. For roof slopes from 2:12 to 4:12, double underlayment is required. Underlayment must conform to ASTM D 226, Type I; ASTM D 4869, Type I; or ASTM D 6757. For slopes of 4:12 and greater, underlayment must be applied shingle fashion. Laps must be a minimum of 2-inches. End laps must be offset by at least 6 feet.

For normal application, strip shingles must be fastened with a **minimum of four nails**. For interlocking shingles, two nails are required. **See the manufacturer's installation instructions.**

Valleys must be lined in accordance with the shingle manufacturers written instructions. In addition, valleys may be of any of the following:

1. For open valleys lined with metal, the valley lining must be at least 24 inches wide and of galvanized steel of at least 26 gage or other approved materials.
2. For open valleys, two plies of roll roofing may be permitted. The bottom layer must be at least 18 inches wide and the top layer at least 36 inches wide.
3. For closed valleys (valleys covered with shingles), valley lining of one ply of smooth roll roofing complying with ASTM D 224 Type II or Type III and at least 36 inches wide or one of the two methods previously listed may be used.

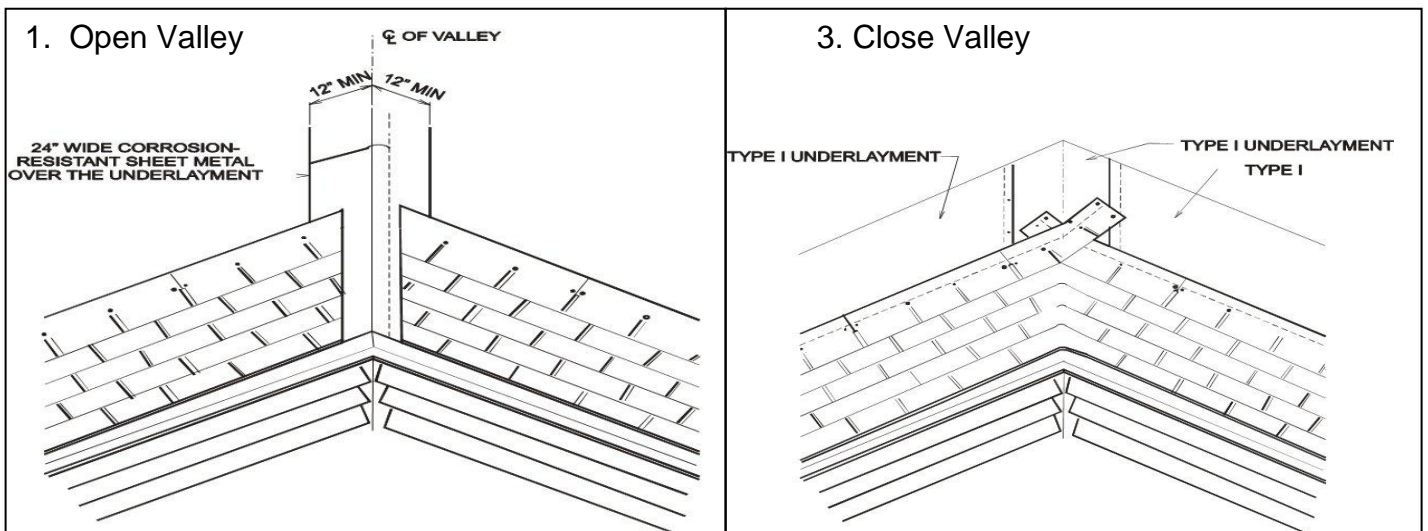

3. Close valley with Shingle cut. See manufacture's instructions.

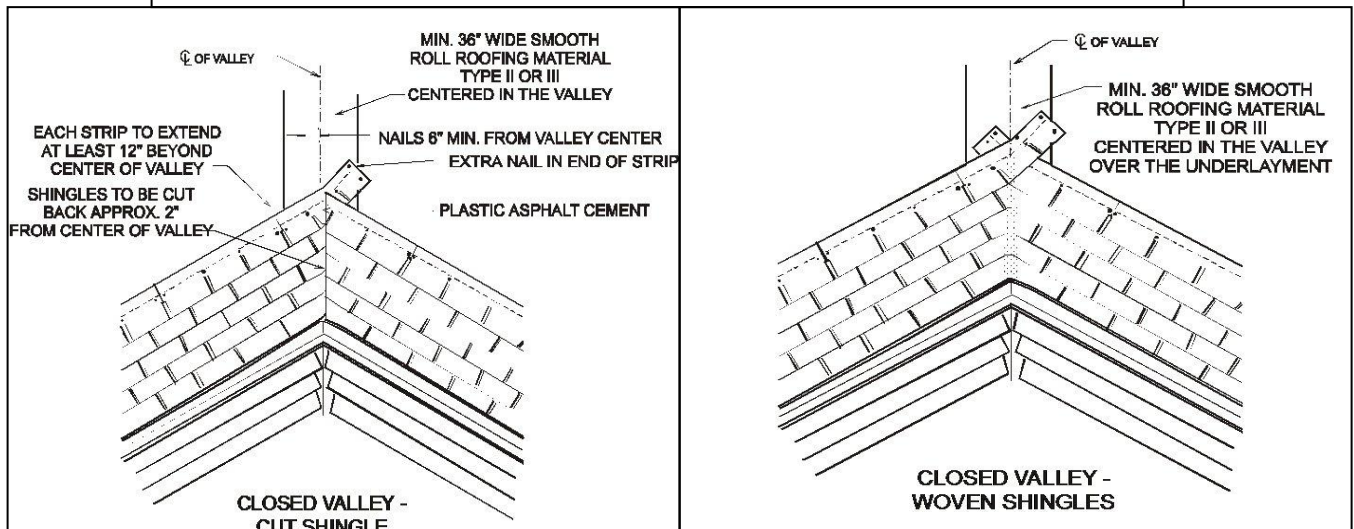

Chimney Cricket required if chimney is more than 30 inches wide

Cricket or saddles are required on the ridge side of any chimney greater than 30 inches wide. Cricket or saddle coverings must be of sheet metal or of the same material as the roof covering. Flashing against a vertical sidewall **must be by the step-flashing method**. Flashing against vertical front walls, soil stacks, vent pipes, and chimney flashing must be in accordance with the asphalt shingle **manufacturer's printed instructions**. (R905.2.8.3) If a cricket is required see Table R1003.20 for cricket dimensions requirements.

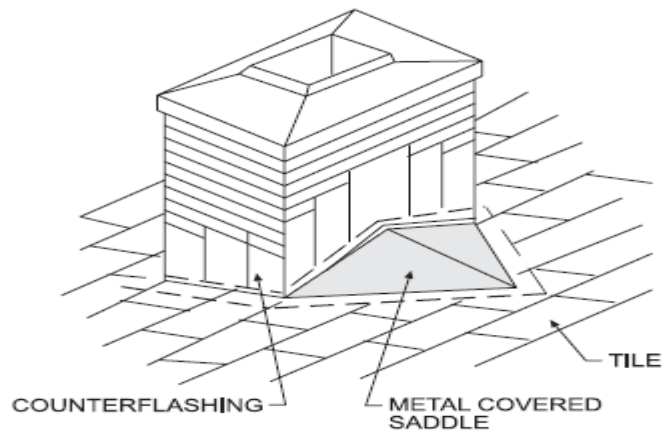

Figure R905.3.8(3)
TILE ROOF CHIMNEY FLASHING DETAIL

MINERAL SURFACED ROLL ROOFING - R905.5

Mineral surfaced roll roofing may only be applied on roofs with a slope of 1:12 or greater.

Mineral surface roll roofing must conform to ASTM D 3909 or ASTM D 6380, Class M.

Mineral surface roll roofing must be installed in accordance with the manufacturer's installation instructions.

REROOFING - R907

All old roof coverings must be removed before installing any new roof coverings. Existing flashing in good condition may be reinstalled. Any sheathing that is replaced must be installed and fastened according to the code.

DEBRIS

The removal of existing roofing materials often results in this debris moving about the neighborhood on windy days. Shingle wrappers and other construction debris are also nuisances to other neighbors when they find this material in their yards. As you install a new roof on your dwelling, we ask that you exercise courtesy towards your neighbors by regularly policing your yard and adjoining areas for debris that may blow around.

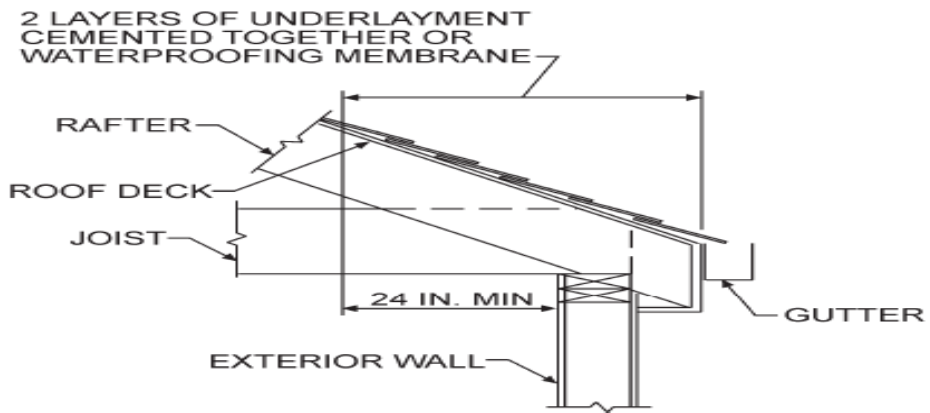
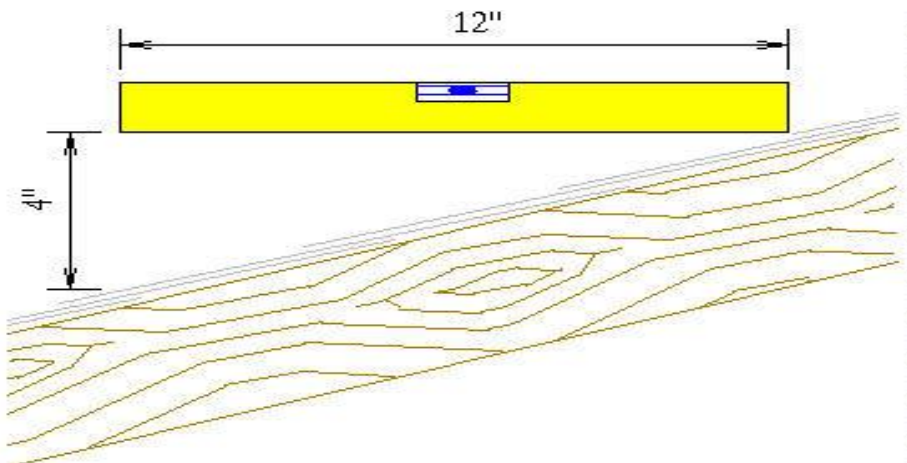
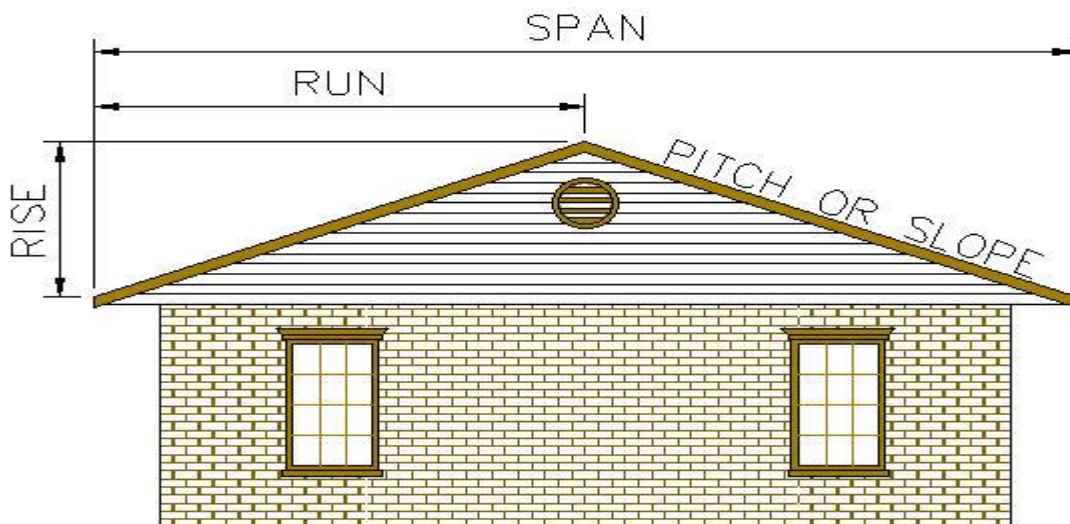

Figure R905.2.7.1(2)
PROTECTIVE ICE BARRIER

Illustrating practices and manufacture's instructions:

A fairly easy way to determine the slope is to take a 12" level and set one end on the roof surface and make it level. Then take a tape measure or ruler and measure from the other end down to the roof surface. This will give you the slope of the roof. The slope of the roof in the following picture would be expressed as "4 in 12" or "4 on 12" and written as 4/12, 4:12, or 4":12".



GOOD BUILDING PRACTICES

ROOF EDGING, GUTTERS, DRAINAGE

Roof edging and gutters are not required by the code. Application of roof edging should be in accordance with the shingle **manufacturers written instructions**. Gutters may be useful in directing water away from buildings reducing erosion, settlement, and wet basements. Lead-outs on downspouts should extend far enough from the building to result in positive drainage.

KICK-OUT FLASHING

The following is an excerpt from the 2007 Minnesota Residential Code:

“R903.2.2 Kick-out flashing/diverter. A kick-out flashing shall be installed where the lower portion of a sloped roof stops within the plane of an intersecting wall cladding, in such a manner as to divert or kick out water away from the assembly.”

Below are a few examples of the installation of kick-out flashing. Kick-out flashing may be either factory made (as shown below) or field fabricated.

