

SINGLE FAMILY RESIDENTIAL DETACHED ACCESSORY STRUCTURE

Floor Plan

Address

Directions

1. Fill in the blanks in pages 2 and 3 with dimensions and materials which will be used to build the structure. Please print legibly.

2. Indicate in the check boxes on page 2 which detail from page 6 will be used.
Note: Heated garages may require special provisions.

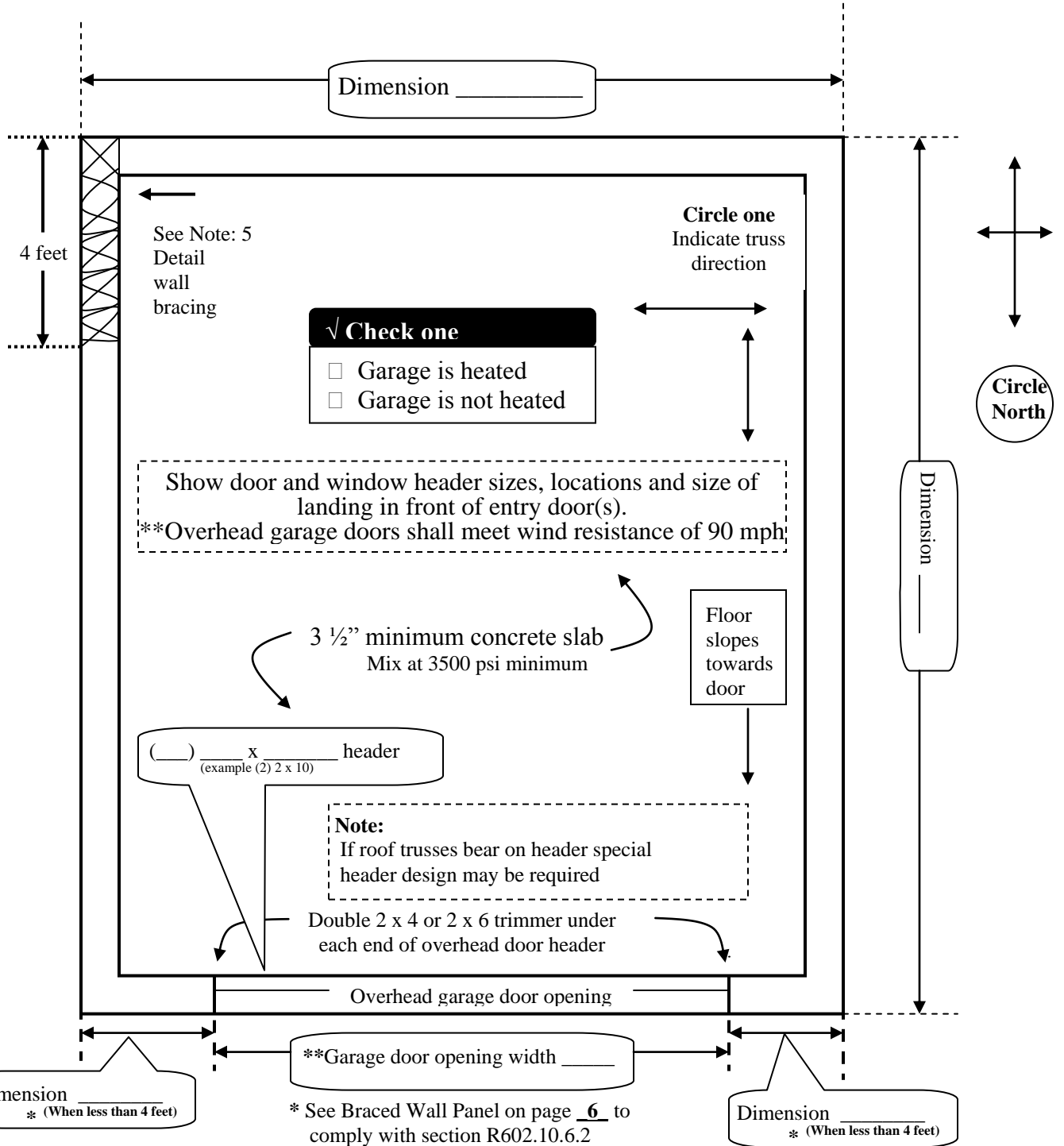

SINGLE FAMILY RESIDENTIAL DETACHED ACCESSORY STRUCTURE

Note: For roofs with slopes less than 4:12, follow manufacture instructions for low slope application of the roof material

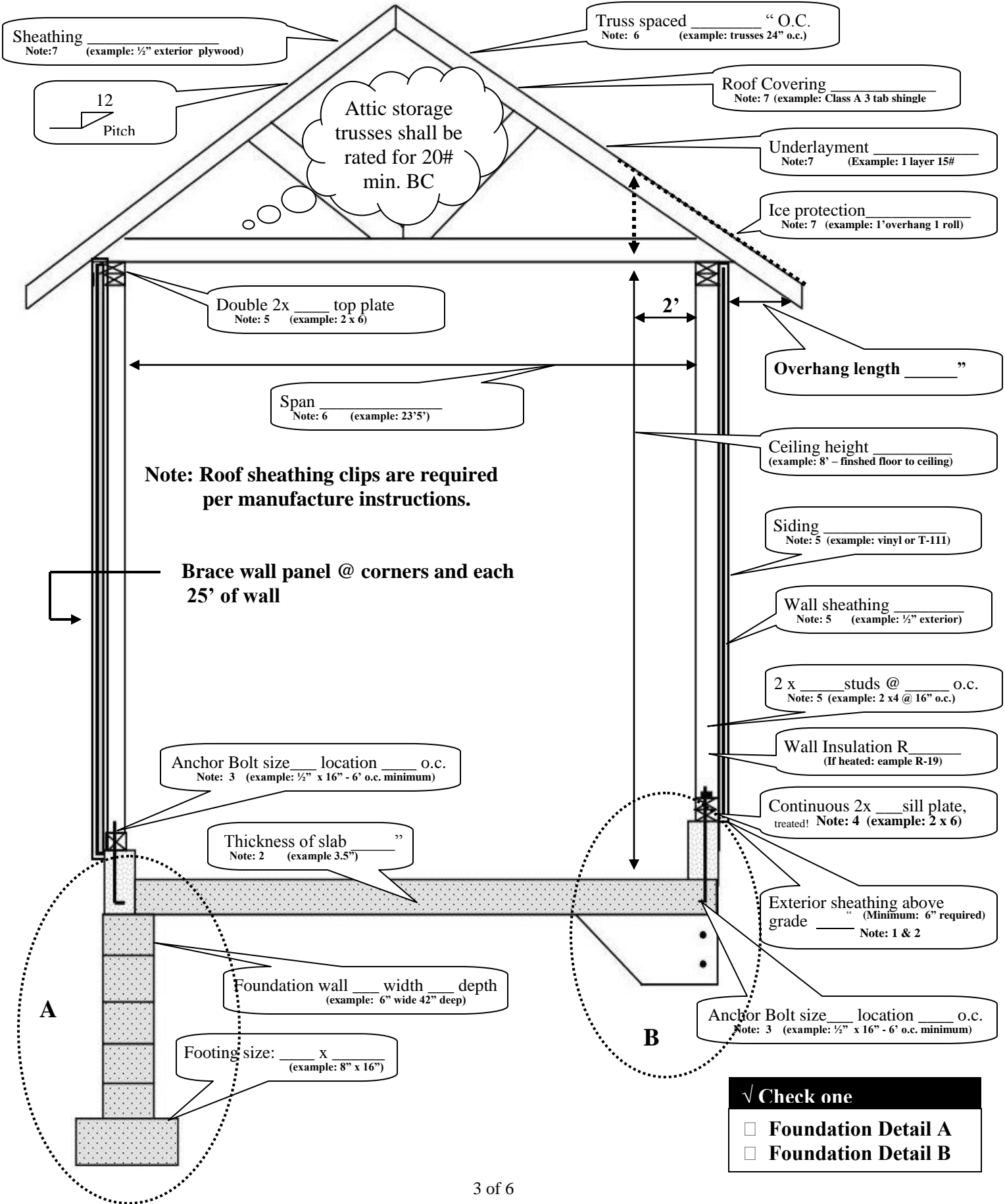

SINGLE FAMILY RESIDENTIAL DETACHED ACCESSORY STRUCTURE

Note #1 – Site/Soil Preparation. All organic material such as grass, roots, etc., must be removed from the area where concrete is to be placed. Soft soils must also be removed and where backfill for subgrade is required a permeable, compacted granular soil, must be used. Do not use fine sand, silty soil or plastic clay as fill material.

To eliminate moisture wicking through the floor it is suggested to install a 6 mil vapor barrier **before** installing the sub-base backfill of 2" to 4" of sand.

Note #2 – Slab/Footing. Detached, private garage less than 1,000 square feet constructed with a foundation system of slab on grade provided that the entire perimeter of the slab is thickened. The slab must be at least 3 ½" thick throughout. The perimeter depth must be at least 12" below the adjacent grade which will leave 6" between exterior soil and the bottom of the exterior siding. Refer to the drawing for typical design A - B.

Alternate design A: Placing a 6" cmu (block) on top of the slab can be used and a the 6" cmu (block) shall be pinned to the slab at anchor bolt locations.

It is suggested that some type of approved reinforcement be installed throughout the slab system.

Note #3 – Sill Plate Anchor Bolts. All wall sill plates (single or double) must be anchored to the slab/foundation system using ½" nominal diameter anchor bolts with nuts and washers. The bolts must be embedded at least 7" into the perimeter concrete. The bolts shall be spaced no more than 6' apart and no less than two bolts per short section of plate are required. Bolts shall be placed within 12" of the ends of plates and within 12" of each side of all intersection corners. Bolts must also be placed on each side of service walk doors. Any other type of anchoring system must be approved by the Building Inspection Division.

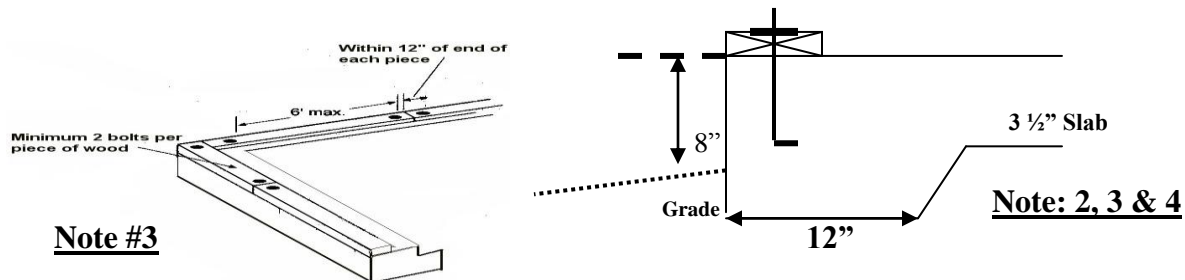

Note #4 – Wall Sill Plates. Wall sill plates that rest on masonry or concrete must be naturally durable wood or wood that is preservative treated if the wall plate is less than 8 inches from the exposed ground. Lumber material shall bear the quality mark of an approved inspection agency.

Note #5 – Wall Framing (Typical). Wall studs shall be framed with their wide dimension perpendicular to the wall. All studs shall have full bearing on a 2" nominal thick sill plate and the sill plate width must be not less than the width of the wall stud. Double top plates must be installed on exterior wall framing and overlapping shall occur at corners and intersecting walls. All splices/end joints of the two plates must be offset at least 24".

Lumber other than utility grade for studs, the following framing schedule will apply: For exterior walls supporting roof and ceiling – 2" x 4" or 2" x 6" either 16" or 24" on center—maximum height of studs shall be 10'. Utility grade studs shall not be spaced more than 16 inches on center, shall not support more than a roof and ceiling, and shall not exceed 8 feet in height for exterior walls and load-bearing walls. Where joists, trusses or rafters are spaced more than 16 inches on center and the bearing studs below are spaced 24 inches on center, such members shall bear within 5 inches of the studs beneath.

SINGLE FAMILY RESIDENTIAL DETACHED ACCESSORY STRUCTURE

Each wall must be thoroughly braced at each end of the brace wall line and at every 25 feet of wall length. The most common method of bracing is: 4' x 8' structural panel (plywood/OSB) sheathing; 7/16" (minimum 5/16") thick for 16" on center framing and (minimum 3/8") thick for 24" on center at each corner and every 25'. All brace wall panels (4'x 8' structural panels) shall be securely and permanently attached to the wall with 8d nails with spacing 6" on center for all edges and 12" on center in the field.

Most siding material (exterior veneer) shall be fastened to framing members using corrosion-resistant fasteners and some type may be allowed to fasten to structural panels. A weather-resistant barrier (house wrap) is required over sheathing. In all instances siding shall be a type of material and finish for weather exposure.

Overhead door headers on gable ends of typical construction such as two 2" x 12" members laminated together will only clear span approximately 16' with a 2' overhang, therefore, it is suggested that if the clear span exceeds 16' the use of a micro-lam beam or similar type construction be employed. Headers supporting roof loads shall be sized accordingly.

Note #6 – Roof Framing. If truss rafters are to be used, a design of the truss showing span, spacing, design loads, etc., must be provided to the Building Inspection Division for review. All truss designs must bear the certification stamp of an engineer currently licensed in the State of Minnesota. Hand framed roof designs shall be submitted for review.

The certified copy of the truss rafter spec sheets shall be provided to the field inspector at the time of framing inspection.

All roof systems must be permanently braced according to WTCA packet that is provided by the truss supplier at the time of roof truss delivery.

Note #7 – Roof Sheathing and Coverings. The most common type of roof sheathing is 7/16" minimum thick 4' x 8' plywood or OSB. All sheathing products shall bear a certification stamp on each sheet from an approved agency noting such things as glue type, exposure type, maximum span of framing members, etc. All roof sheathing must be covered with at least 15lb. felt prior to shingle application. Be advised that some shingle manufacturers require an ice barrier under their shingle at the beginning edge of the roof. When roof slope is less than 4 inches in 12 inches application of the underlayment felt will be applied differently. Refer to shingle manufacturer's installation instructions for underlayment requirements. If the structure is heated, ice dam protection shall extend from the fascia to two feet past the inside of the exterior wall.



Note #8 - Truss to Wall Connection. Trusses shall be connected to wall plates by the use of fasteners or connectors having a resistance to uplift of not less than the value listed on the truss design drawings. Example: Three - 16d common nails connecting truss to SPF top plate has the value of 111 lb. uplift. Example: (16d common nail is .162 diam. x 3.5" long) Splitting the heel of the roof truss with nail penetrations voids uplift restraints. Design connectors eliminate this splitting problem and shall be installed per listing.

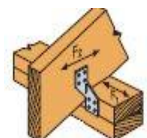

SINGLE FAMILY RESIDENTIAL DETACHED ACCESSORY STRUCTURE

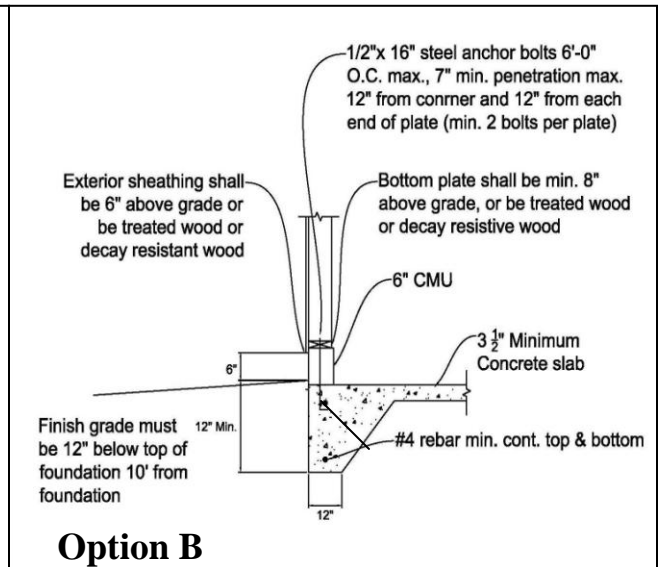
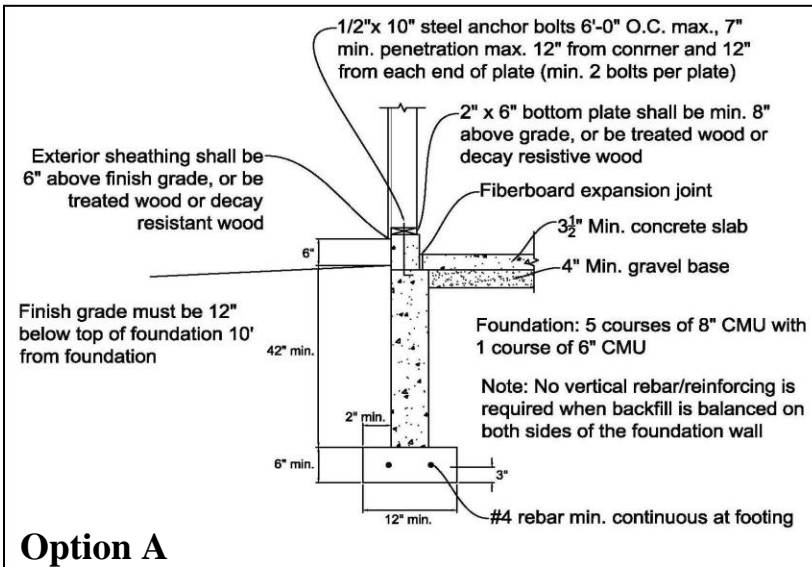

Braced Wall Panel Detail

NARROW WALL OVER CONCRETE OR MASONRY BLOCK FOUNDATION

