

# Residential Decks

1 & 2 Family Dwellings and Townhouses

City of Owatonna

BUILDING DEPARTMENT

507- 444-4370

[www.ci.owatonna.mn.us](http://www.ci.owatonna.mn.us)

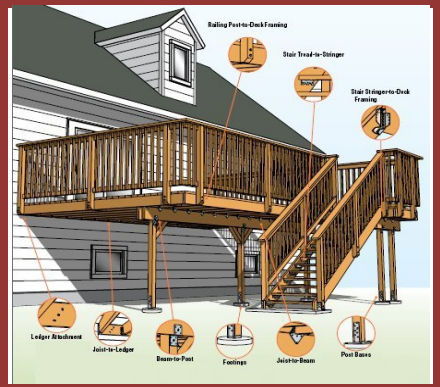

This handout is intended only as a guide and is based in part on the 2007 Minnesota State Building Code, and the City of Owatonna ordinances and good building practice. While every attempt has been made to insure the correctness of this handout, no guarantees are made to its accuracy or completeness. Responsibility for compliance with applicable codes and ordinances falls on the owner or contractor. For specific questions regarding code requirements, refer to the applicable codes or contact your local Building Department.

## Building Permits Requirements:

Building permits are required for the construction of all decks that are attached to the home and for freestanding decks that are elevated 30" or more above grade. A zoning permit is required for deck construction that is exempt from Building Permits. Deck construction shall meet the requirements of the 2007 Minnesota State Building Code which adopts and amends the 2006 International Residential Code.

## Zoning Requirements:

Decks are also required to meet the land use and setback requirements of the zoning code.

Zoning questions should be directed to the City Planning, Zoning Office, 507.444.4340 .

## Plan Review & Inspections:

The plan is reviewed by the plans examiner in order to identify potential problems that may arise prior to construction. Construction inspections will be done during the project to ensure code compliance and that the materials used are installed correctly.

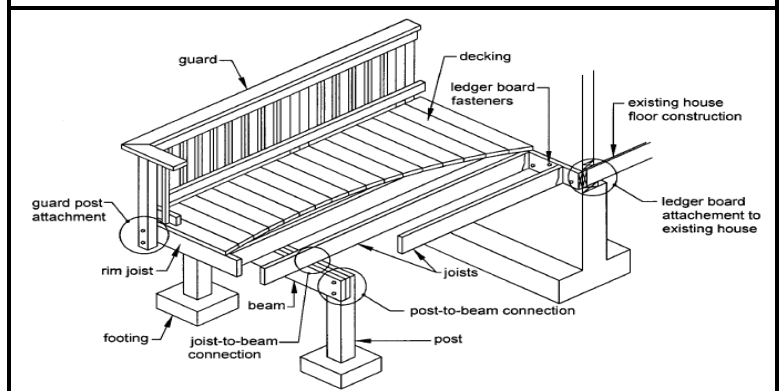
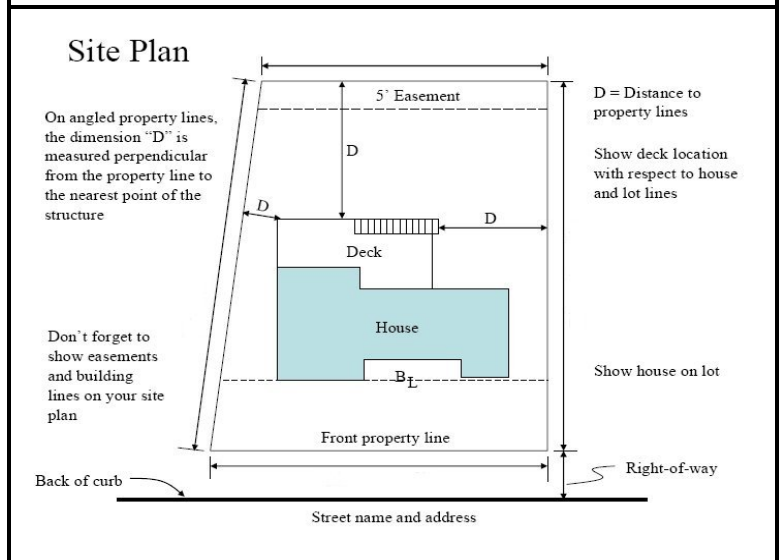
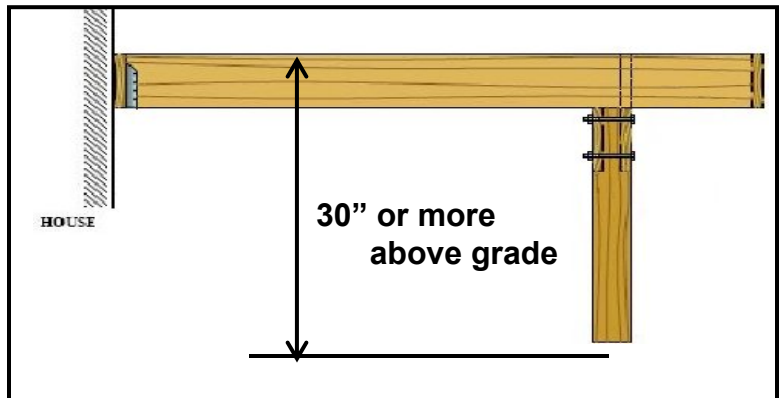



***Builders and homeowners are required to obtain a permit prior to constructing, altering or replacing a deck.***



The following are examples of information that should be included on plans submitted for building permits for residential decks. They are **examples** only and should not be construed as being code compliant for every application. It is the responsibility of the homeowner or person preparing the plans to show in detail how they will build their deck. Some designs may require more detail than others.

Your deck plans should replicate exactly how you will build your deck. We will review your plans before we issue the building permit to verify code compliance before you start work. The more detailed your plans, the more likely you will avoid mistakes during construction.

When you receive your permit, you will also be given one set of plans stamped "Approved". Once your plans are approved, you should not change your design without approval by the City of Owatonna Building Inspection Division. ***You should read through the approved plans to determine if the plan reviewer noted any corrections to your plan.*** If you have any questions regarding any of the corrections you should contact us before proceeding. **Stamped approved deck plans shall be readily accessible at all inspections.**



***Permit holder is responsible for scheduling all inspections.***



Plans created at home centers are seldom acceptable for plan review. These computer designs do not allow homeowners to duplicate actual conditions at their home. Some of these plans may be modified to include all necessary information prior to submittal. Applications submitted with these types of plans without additional modifications will be returned to the applicant.



**THINK YOU MIGHT ENCLOSE YOUR DECK IN THE FUTURE?**

Deck plans are approved on the assumption that the deck will be used only as a deck for the life of the structure. Because footing sizes, setbacks, structural supports and a host of other deck components are different for enclosed porches than for decks. It is important that you indicate on your plans the desire to convert the deck at a future date. You should then design your deck to carry future loads and meet setbacks and other rules.

**TYPICAL DECK CROSS SECTION  
CITY OF OWATONNA**

**Note: All flashing, fasteners and connectors must be compatible with materials used.**

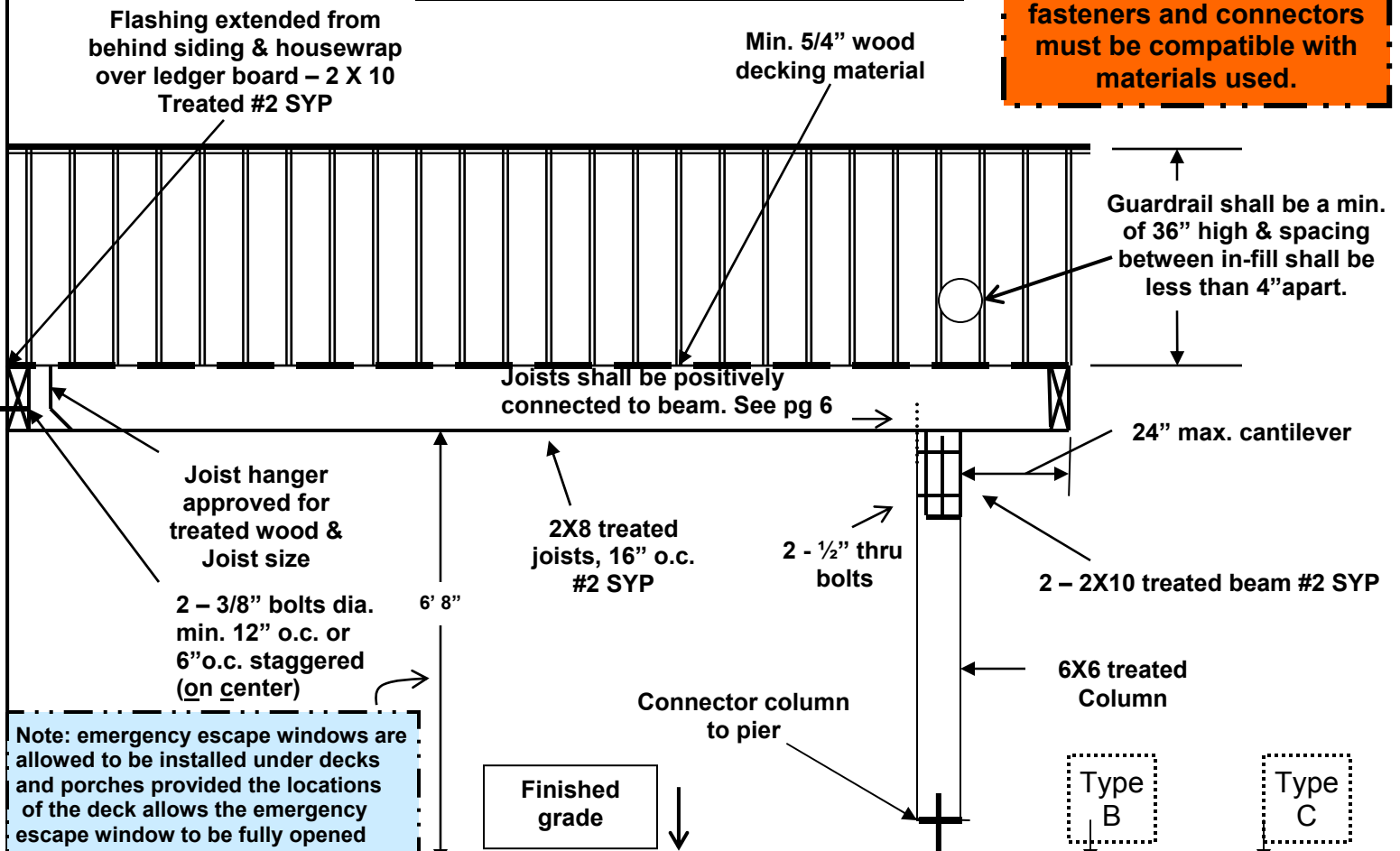

Note: emergency escape windows are allowed to be installed under decks and porches provided the locations of the deck allows the emergency escape window to be fully opened and provides a path not less than 36" in height to a yard or court. 6'8" required for walk out basements or patios.

**FOOTINGS**

**BeFore you Dig** Call Gopher State One for utility locations at least two working days **before you dig** - 1-800-252-1166 or 651-454-0002.

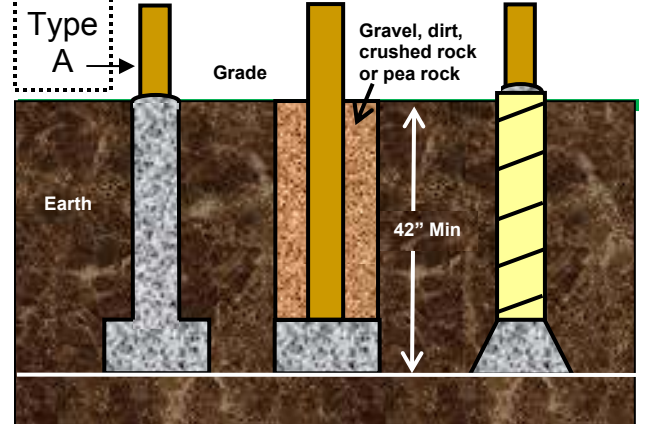
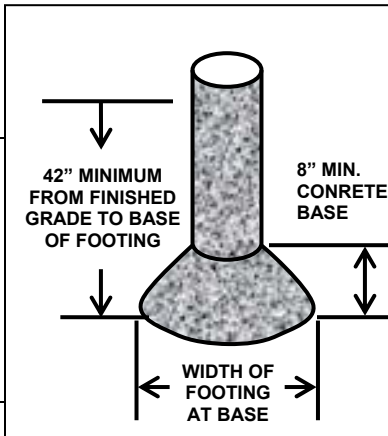

**To accurately size footings, beams and joist refer to tables on pgs 11-13.**

**Beam and Footing Sizes**

**Maximum Joist Span**

Footings supporting a 4x6 column must be not less than 8-inch diameter. Post footings supporting columns larger than 4x6 must be not less than 8-inch diameter. The bottom of post footings may be "belled" to achieve the desired minimum bearing area. The base of the footing must be at least 42 inches below finished grade. Care should be exercised to center the column on the footing. Posts imbedded in the ground must be labeled ground contact or equal. The use of a fiberboard tube will allow you to elevate the top of the footing above finished grade to provide protection of the wood post from lawn mowers and trimmers.



**WARNING: THIS IS AN ILLUSTRATION ONLY. IT IS INTENDED TO SHOW SOME OF THE INFORMATION THAT SHOULD BE INCLUDED ON YOUR DECK PLANS. IT IS NOT INTENDED TO SHOW COMPLIANCE WITH ANY CODES THAT MAY APPLY. CHANGES IN THE HEIGHT AND SIZE OF A DECK WILL CAUSE VARIATIONS IN CODE REQUIREMENTS.**

# DECK FRAMING

## Ledger Board Connection

The ledger board attaches to the house frame or foundation. **Make sure the ledger is securely attached to the dwelling. Install metal flashing at top, and caulk sides and bottom.**

### General Attachment of Ledger Board to House Band Joist/Rim Board

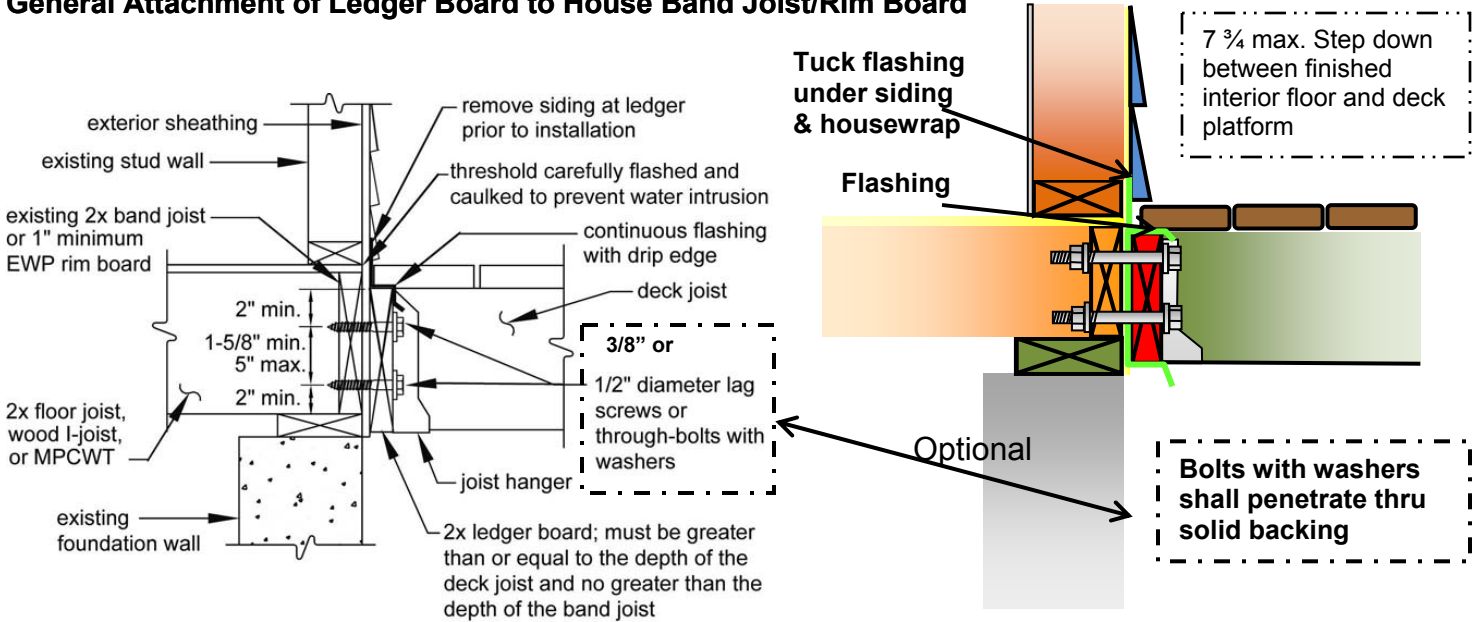

**CONCEALED FLANGE HANGER**

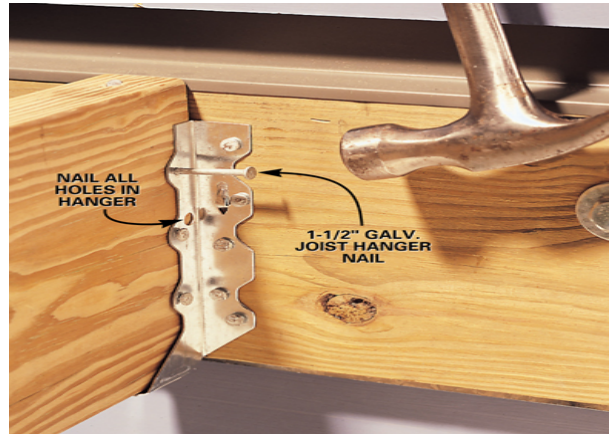

**CONVENTIONAL HANGER**

**No Attachment to or Through Exterior Veneers (Brick, Masonry, Stone)**

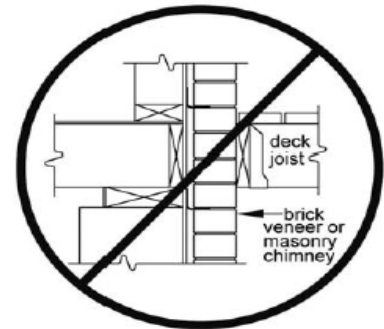

**Metal Plate Connected (MPC) Wood Floor Trusses with a 2x4 Lumber "Ribbon" at the Ends of the Trusses**

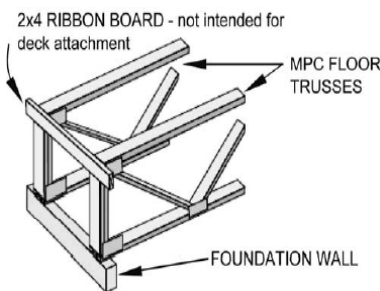

**No Attachment to Over Hangs**



# Understanding Load Paths

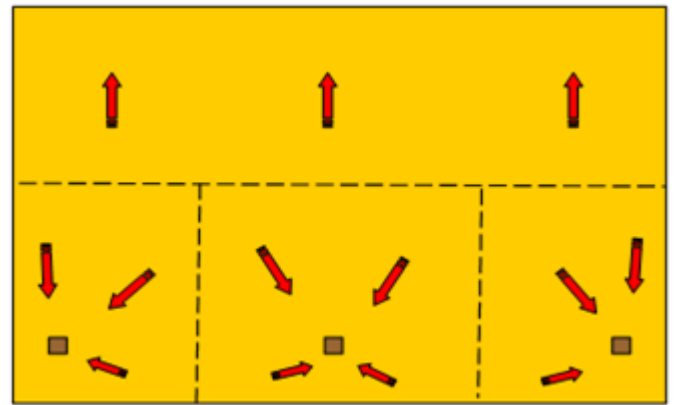
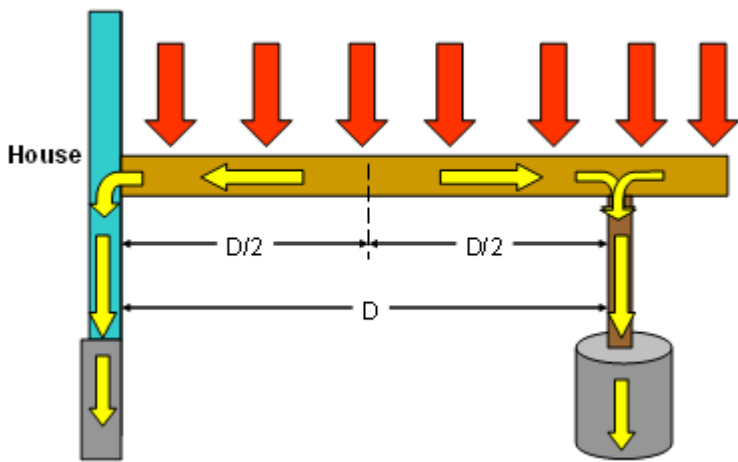

Loads are assumed to be uniform across the floor

## Tributary load area for posts

B = Beam span  
C = Joist span

Tributary is half the distance: of the joist or to the post.

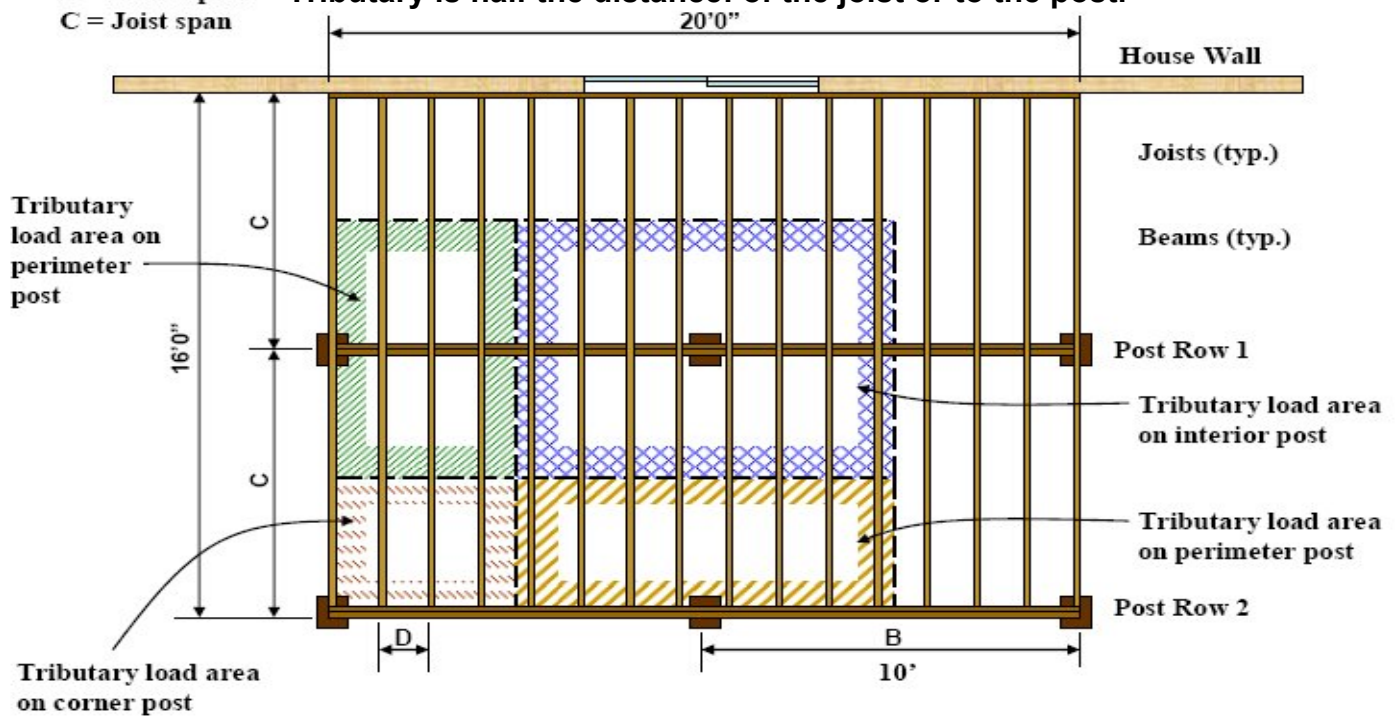

THE REQUIRED AREA OF THE COLUMN SHOULD FULLY BEAR ON THE FOOTING

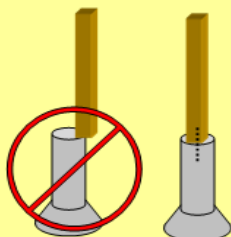

★ HINT: PLACING A SLIGHT CROWN ON THE TOP OF THE FOOTING PREVENTS WATER ACCUMULATIONS AND PREMATURE COLUMN FAILURE.

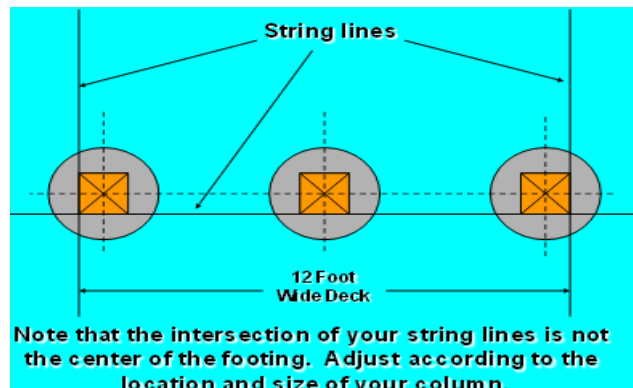

Note that the intersection of your string lines is not the center of the footing. Adjust according to the location and size of your column.

# Attaching: Beam to Post

## Illustrations

Beam Pocket Cut Into A 6 X 6 Support Post

Type A

METHODS OF ATTACHING BEAM TO COLUMN



BEAM SECURED WITH POST CAP

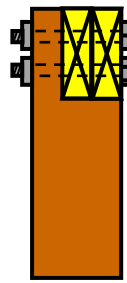

BEAM SECURED WITH BOLTS TO NOTCHED POST

Type B

Section View

Elevation View

Top View

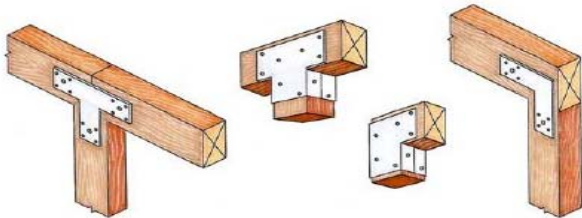
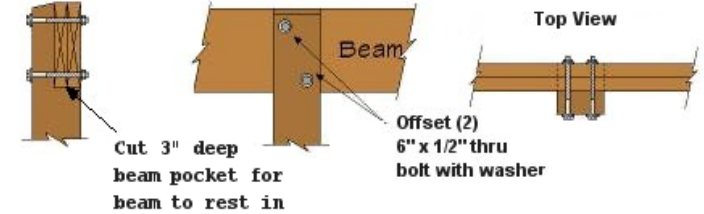

POST-TO-GIRDER CONNECTIONS

Type C

### BEAM SPLICES

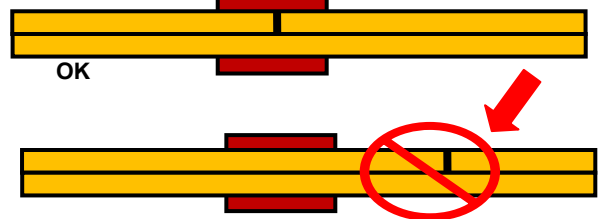

Construct the beam using two or more 2 inch nominal pieces of lumber. Nail the beam together using 10d - 16d nails at 16 inches o.c. along each edge of the beam. A spacer may be used to fir the beam to a 3½ -inch width. Beams should be installed with any arch or crown facing up.

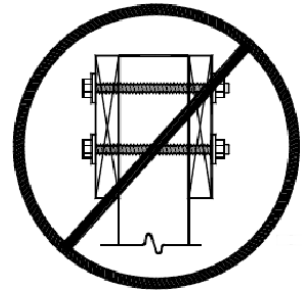
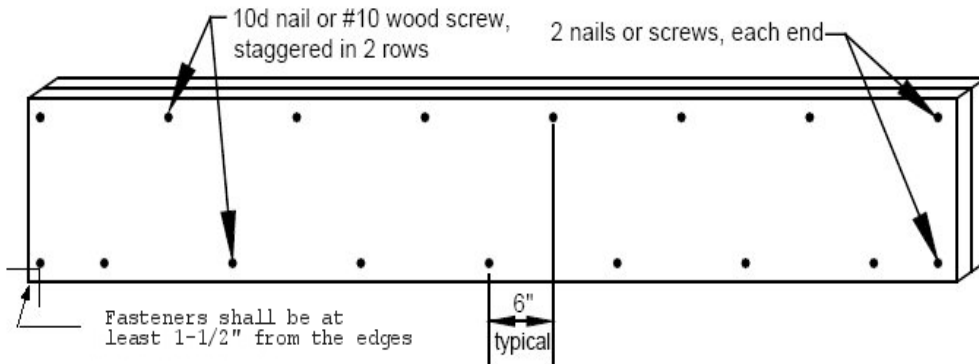

### JOIST-TO-BEAM CONNECTION

Each joist shall be attached to the beam as shown. Use Option 1 or Option 2 when joists bear on or overhang past the beam. Use Option 3 when joists attach to the side of the beam.

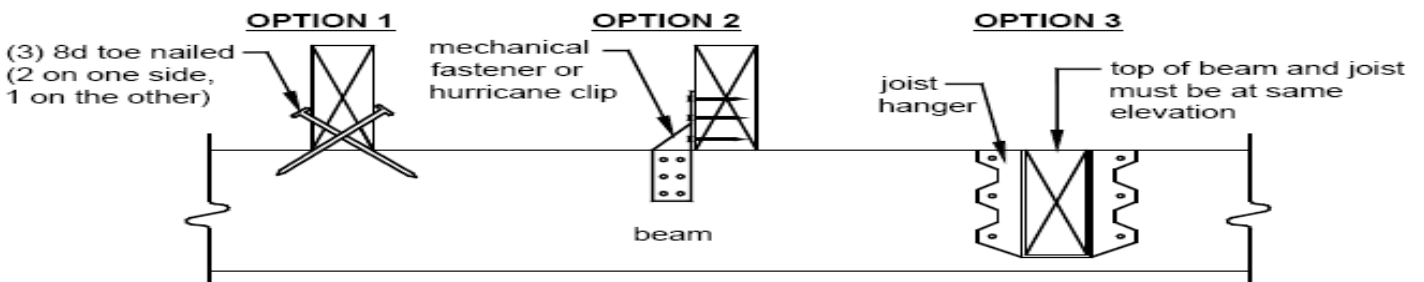

# Cantilever Options

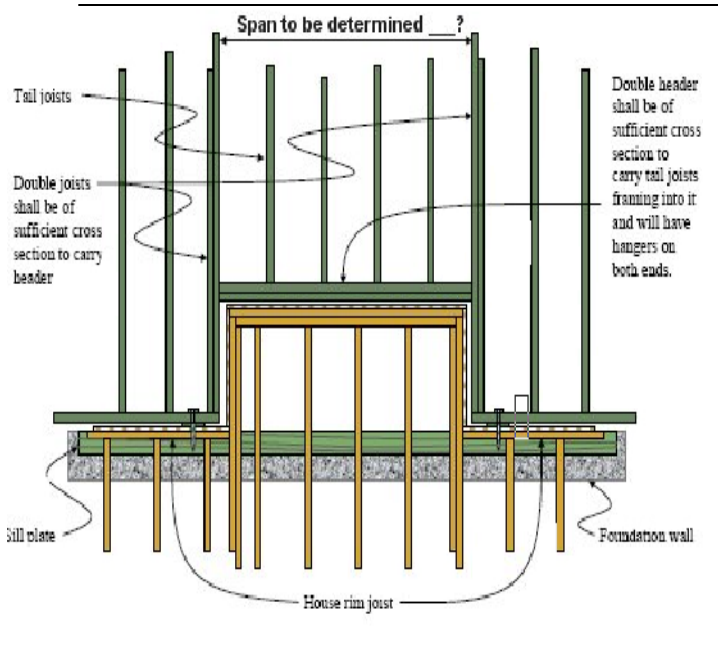

## Cantilevered connection

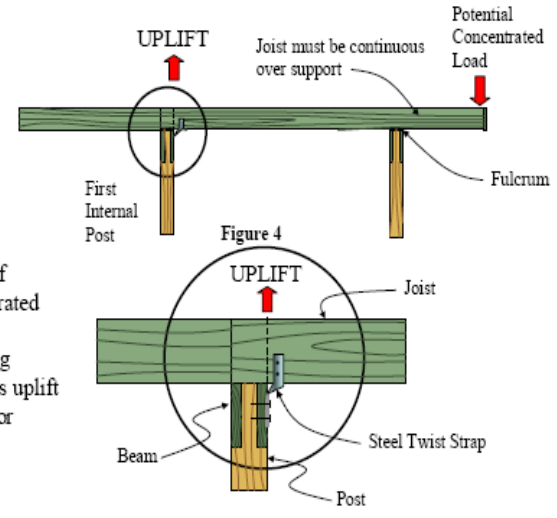

**All thru bolts and lag screws shall be installed with washers.**

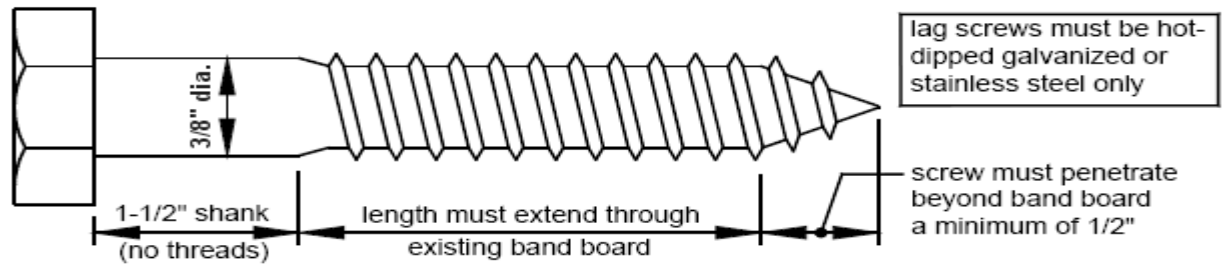

Lag screws or bolts shall be placed two inches from the bottom and top of deck ledgers and between two to five inches from the ends. Lag screws or bolts shall be staggered from the top to the bottom along the horizontal run of the deck ledger.

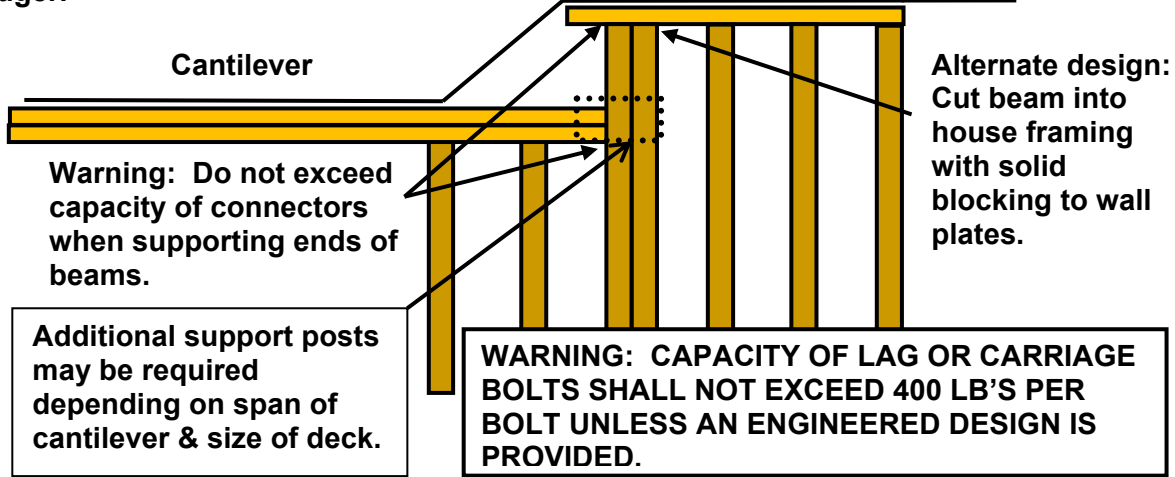
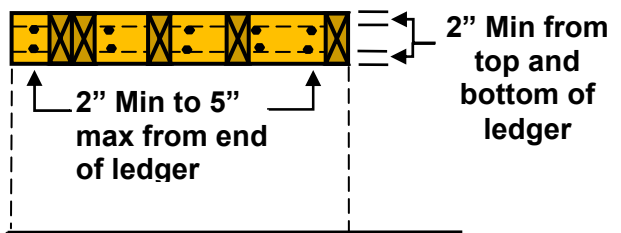

# A TYPICAL STAIR FRAMING DETAIL

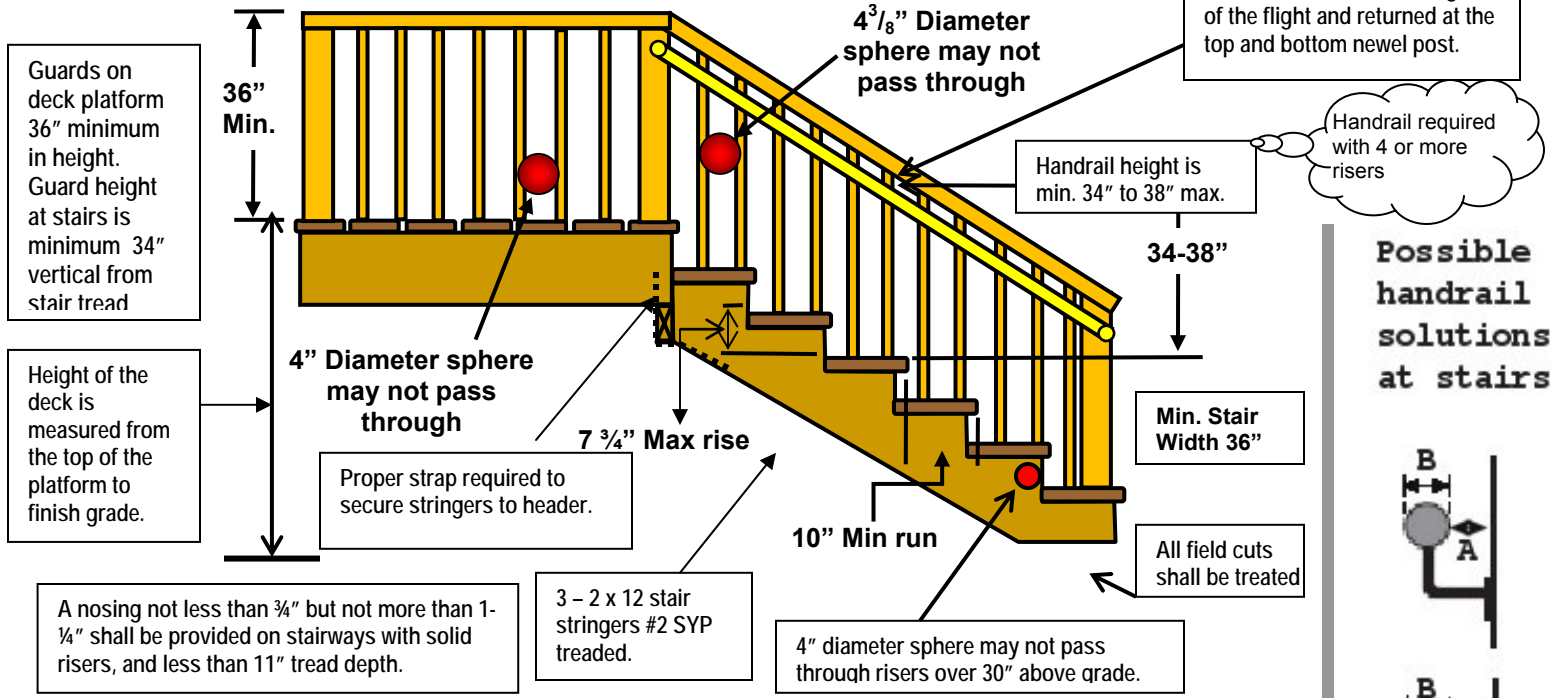

Stairway illumination. All interior and exterior stairways shall be provided with a means to illuminate the stairs, including the landings and treads. The illumination of exterior stairways shall be controlled from inside the dwelling unit. Lights that are continuously illuminated or automatically controlled can be used. Solar lighting is NOT approved. ★★

## Reinforced Post Connections (Three dimensional view)

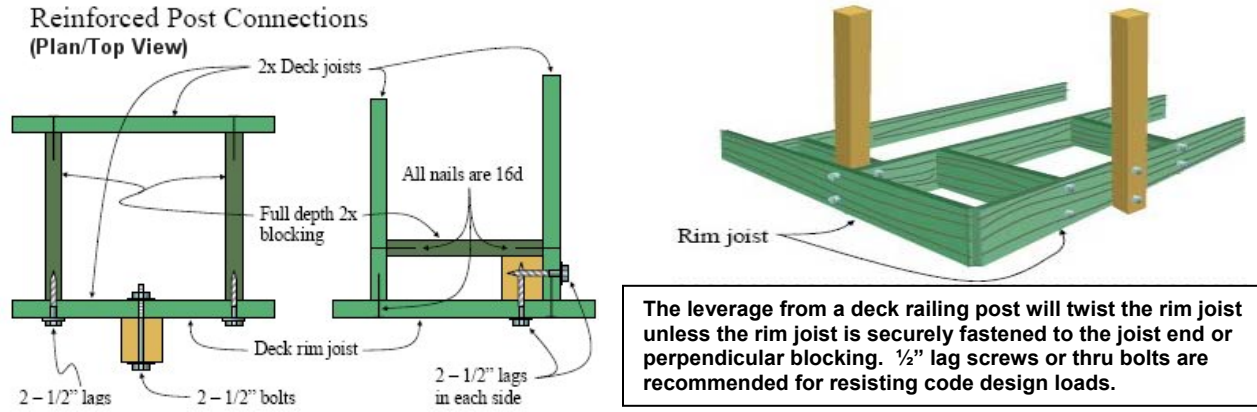

## Possible handrail solutions at stairs

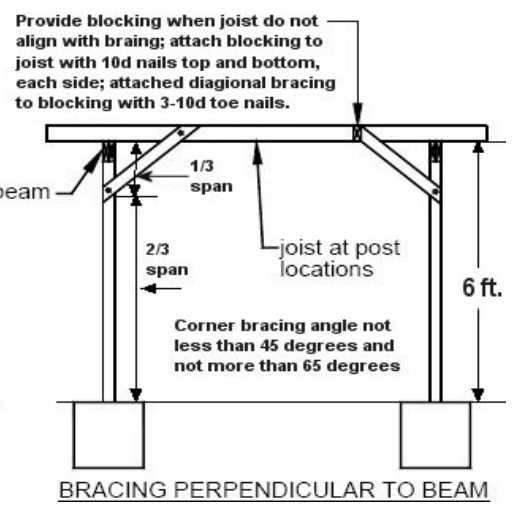
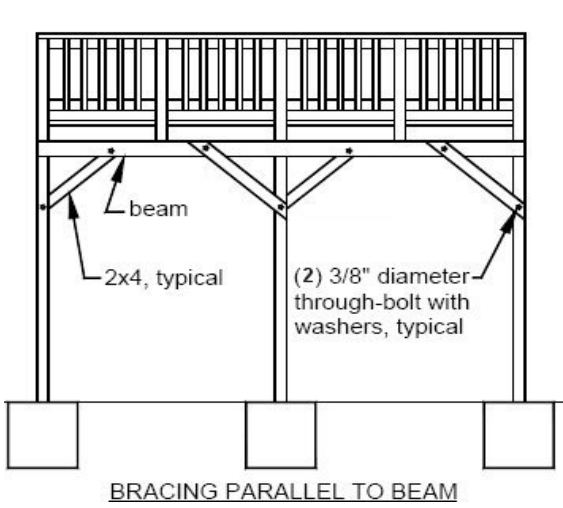
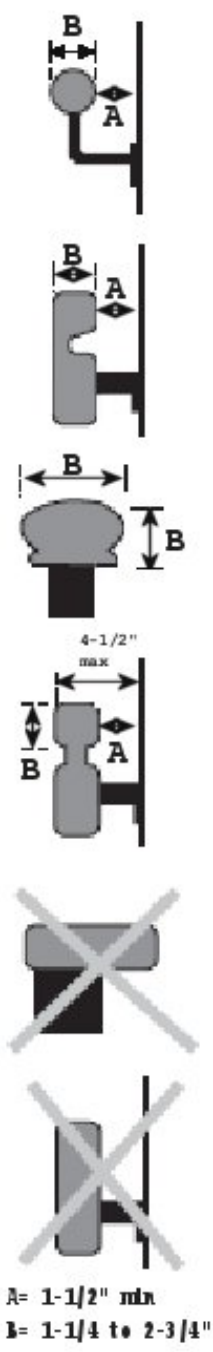

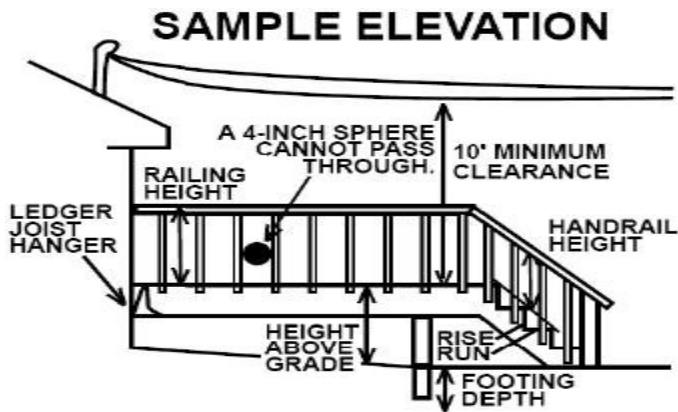

Electrical service lines over or within 3' horizontally of the deck or stairs *must* have a minimum 10' vertical clearance.

## RAILINGS

Guardrails are required for portions of decks 30" or more above grade. The height of the rail must be a minimum of 36". Open guardrails must have intermediate rails or an ornamental pattern that a 4" sphere cannot pass through. Guardrails must continue down stairs where the stair is more than 30 inches above grade.

## STAIRS

Stairs must have a maximum rise of  $7\frac{3}{4}$  inches and a minimum run of 10 inches. The run is measured from the nosing of one tread to the nosing of the next. The greatest riser height within any flight of stairs shall not exceed the smallest by more than  $\frac{3}{8}$  inch. The greatest tread depth within any flight of stairs shall not exceed the smallest by more than  $\frac{3}{8}$  inch.

**Maximum step down** is  $7\frac{3}{4}$ " from interior finished floor to top of the deck platform at the patio door.

Open risers are permitted provided that a 4" diameter sphere will not pass thru the opening between the treads.

## SAFETY GLAZING

**All glass (windows) shall be reviewed for tempered glazing requirements. Be sure to show location of all windows in relation to deck stairs, landings, top and bottom treads, and walking surfaces.**

## Wood Treatment

Wood used above ground, in contact with the ground, or below ground requires different degrees of treatment. Check the labels of the material you are buying to determine where it can be used. ***Because the new preservative treatments are very corrosive, make sure that any metal connectors used in the construction of your deck are approved by the manufacturer for use with treated wood.***

## Decking

Materials commonly used for decking include standard dimension lumber (either 2X4 or 2X6), radius-edged decking, or a manufactured decking product. ***2X6 dimension lumber is the only lumber product that can be used on joist spacing of 24 inches.***

Radius-edged Patio Decking has been specifically developed for outdoor decks. ***Patio decking is intended to be used flat-wise in load-bearing applications where joist spacing does not exceed 16" o.c. (12" o.c. when installed diagonally to joists).***

***Manufactured decking products may be used only when approved by the Building Department.*** This approval is based on the material carrying an NER research report. Decking without a research report will not be approved. Ask the decking supplier to provide you with a copy of the research report. The Building Department maintains a list of decking materials that have been approved for use in Minnesota that is available upon request. ***Caution – some manufactured deck products are approved for decking but not for stair treads. In some cases where manufactured decking is approved for stairs, the spacing of supports***

**may be significantly reduced compared to use on the deck itself. Read the research report for further information.**

<b>MAXIMUM DECK BOARD SPANS</b>	
<b>5/4 AND 2X4 PERPENDICULAR TO JOIST</b>	<b>16" O.C.</b>
<b>5/4 AND 2X4 AT 45 DEGRESS TO JOIST</b>	<b>12" O.C.</b>
<b>2X6</b>	<b>24" O.C.</b>



## **INSPECTIONS**

The Building Department will typically make at least two inspections of your deck. It is your responsibility to call for an inspection 1-2 days in advance of the time you need an inspection. When you call for an inspection, you will be asked for your address, the type of inspection you desire (footing, framing, final), the permit number (which is found on your building permit and inspection record card), and the time you want the inspection. We will make every effort to accommodate requests for inspections at specific times.

Permit holder is responsible for scheduling all inspections.

The first inspection will be of the post footings. At the time of the inspection, property pins shall be exposed, the holes should be dug and all loose material should be removed but no concrete should be poured. The inspector will check the depth of the footing and it's width at the base. They shall also check the location of the footings for compliance with the zoning ordinance. If you are having problems with water seeping into the hole, you may wish to insert a large plastic garbage bag into the hole and pour the concrete into the bag to displace water without compromising the concrete.

The next inspection is the framing and final inspection. The inspector will check the size and spacing of joists, beams and columns, the attachment to the dwelling including flashing, the type of fasteners and lumber being used, type of decking used, railings, stairs, and landings. If your deck will be built such that the underside of the deck will not be visible or accessible at the final inspection, or you wish to have a framing inspection done prior to installation of decking and rails, please call for that inspection.

The inspection record card and approved plans must be available whenever an inspection is made. The inspector will sign the record card if the work is approved and this will be your authorization to proceed to the next step. If you will not be present for the inspection, place the record card and plans near the worksite where they can be found by the inspector. This record card will also provide documentation for you that your deck was inspected and approved. Common correction orders include lack of or improperly attached connectors; composite decking instructions not on site; composite decking used for stair treads in conflict with manufacturer's directions; lack of handrails; stair rise/run not compliant; no grippable handrail or discontinuous handrails; 4 inch spacing for guards and risers exceeded; no flashing at the ledger; beam splices not over column; and stair stringers not securely attached. Please make sure these issues are all addressed before calling for a framing or final inspection.

If a violation is detected a notice will be prominently placed at the site noting the correction that must be made and time limit allowed for corrections. The notice will also indicate if a re-inspection will be necessary. If a re-inspection is necessary you must call for the inspection and have the correction approved before proceeding unless directed otherwise by the inspector.

If at any time during the construction of your deck you have a question, please do not hesitate to call the Building Department at (507) 444-4370. We will be happy to meet with you on the site to help resolve any concerns or problems.

**SIZING DECK COMPONENTS – REFER TO TABLES FOR JOIST, BEAM AND FOOTING SIZE REQUIREMENTS ON THE FOLLOWING PAGES. SEE TABLES ON PAGES 12 & 13.**

**Example 1:  $a = 12'$ ; Post Spacing =  $8'$**

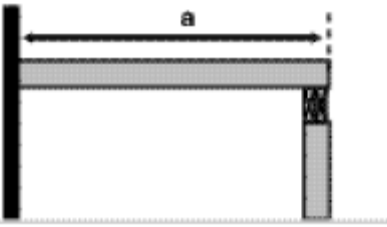

Use the **Maximum Joist Spans** table to find the acceptable joist sizes for a 12' span based on the species of lumber your supplier offers, e.g. Southern Pine 2x8s spaced at 16" on center (O.C.).

Use the **Beam and Footing Sizes** table and find the 8' post spacing column. With a 12' total joist length, the beam may be either two 2x10s or two 2x12s depending on wood used. The footing diameter at the base must be a minimum of 12" for each corner post and 17" for all intermediate posts.

**Example 2:  $a = 8' + b = 2' = 10'$ ; Post Spacing =  $8'$**

Use "a" to determine joist size and "a" + "2b" to determine beam and footing sizes. The length of "b" is restricted by both the length of "a" and the size of the joists.

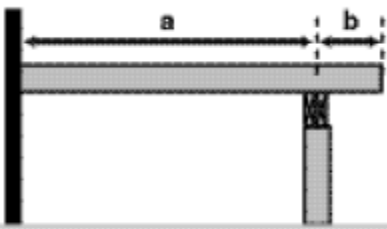

Refer to the **Maximum Joist Spans** table. For an 8' joist span, 2x6s from any species could be used with 16" O.C. spacing.

For sizing the beam, use a joist length of 10' (8' + 2') and a post spacing of 8'. The **Beam and Footing Sizes** table indicates that the beam may be either two 2x10s, depending on the wood species used. The footing diameter at the base must be a minimum of 11" for each corner post and 16" for all intermediate posts.

**Example 3:  $a = 6'$ ,  $b = 7'$ ; Post Spacing =  $9'$**

Use "a" or "b", whichever is greater, to determine joist size. Use "a" + "b" to determine the size of Beam 1 and the post footing size for the footings supporting Beam 1. Use joist length "b" to determine both the size of Beam 2 and the post footing size for the posts supporting Beam 2.

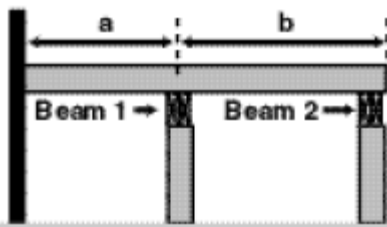

Joist size is determined by using the longest span joist (7'). The **Maximum Joist Spans** table indicates that 2x6 spf spaced at 16" O.C. would be adequate for this span.

For Beam 1 and footings, use a joist length of 13' (6' + 7') and a post spacing of 9'. The **Beam and Footing Sizes** table indicates that the beam may be two 2x12s or three 3x12s depending on the wood species used. The footing diameters for Beam 1 posts shall be a minimum of 13" for the corner (outside) posts and 19 for all intermediate posts.

For Beam 2 and footings use a joist length of 7' and post spacing of 9'. The beam may be two 2x8s or two 2x10s depending on the wood species used. The footing diameters for Beam 2 must be a minimum of 10" for the corner posts and 14" for all intermediate posts





**MAXIMUM JOIST SPANS (A 2-FOOT CANTILEVER CAN BE ADDED)**  
**SEE NEXT PAGE FOR BEAM AND FOOTING SIZES**

Table assumes on No. 2 or better wood grades. Naturally decay resistant or treated for weather and/or ground exposure.

(Design load = 40 psf LL + 10 psf DL, Deflection = L/360, total load Deflection L/240)

Species or Group	2 x 6		2 x 8		2 x 10		2 x 12	
	spacing on center		spacing on center		spacing on center		spacing on center	
	12"	16"	12"	16"	12"	16"	12"	16"
Southern Pine	10'-9"	9'-9"	14'-2"	12'-10"	18'-0"	16'-1"	21'-9"	18'-10"
Douglas Fir-Larch	10'-9"	9'-9"	14'-2"	12'-7"	17'-9"	15'-5"	20'-7"	17'-10"
Douglas Fir-South	9'-8"	8'-10"	12'-10"	11'-8"	16'-4"	14'-10"	19'-11"	17'-5"
Hem-Fir	10'-0"	9'-1"	13'-2"	12'-0"	16'-10"	15'-2"	20'-4"	17'-7"
Spruce-Pine-Fir	9'-6"	8'-7"	12'-6"	11'-4"	15'-11"	14'-6"	19'-4"	16'-0"
White - Woods	9'-2"	8'-3"	12'-0"	10'-11"	15'-5"	13'-6"	18'-0"	15'-7"

**Stamp Lumber Species**

<b>Western Woods -</b>	<b>West Wood</b>	<b>Southern Pine</b>	<b>White Woods -</b> <b>WW</b>
<b>SPFs</b> Spruce-Pine-Fir (South)		<b>SYP</b> Southern Yellow Pine	 Ponderosa Pine-Sugar Pine
 Douglas Fir-Larch			 Ponderosa Pine-Lodgepole Pine
 Douglas Fir-South			
 Hem-Fir			

**Identification of Preservative-Treated Wood**  
**Section 2303.1.8.1 & R319.2**  
**2006 International Building & Residential Code**

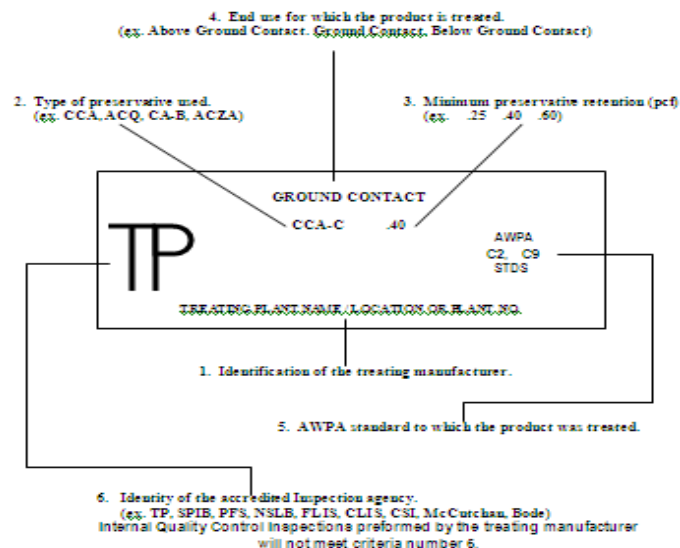

**All pressure treated wood shall be properly identified with a fastened label or stamped with a quality mark.**

# BEAM AND FOOTING SIZES

	Species or Group	Post Spacing										
		4'	5'	6'	7'	8'	9'	10'	11'	12'	13'	14'
6'	Southern Pine Beam	(2) 2x6	(2) 2x6	(2) 2x6	(2) 2x6	(2) 2x8	(2) 2x8	(2) 2x8	(2) 2x10	(2) 2x10	(2) 2x12	(2) 2x12
	Ponderosa Pine Beam	(2) 2x6	(2) 2x6	(2) 2x6	(2) 2x8	(2) 2x8	(3) 2x10	(2) 2x12	(2) 2x12	(3) 2x12	(3) 2x12	(3) 2x12
	Corner Footing	6	7	7	8	9	9	10	10	10	11	11
	Intermediate Footing	9	10	10	11	12	13	14	14	15	15	16
7'	Southern Pine Beam	(2) 2x6	(2) 2x6	(2) 2x6	(2) 2x6	(2) 2x8	(2) 2x8	(2) 2x10	(3) 2x8	(2) 2x12	(3) 2x10	(3) 2x12
	Ponderosa Pine Beam	(2) 2x6	(2) 2x6	(2) 2x6	(2) 2x8	(2) 2x10	(2) 2x10	(2) 2x12	(3) 2x12	(3) 2x12	(3) 2x12	(3) 2x12
	Corner Footing	7	7	8	9	9	10	10	11	11	12	12
	Intermediate Footing	9	10	11	12	13	14	15	15	16	17	17
8'	Southern Pine Beam	(2) 2x6	(2) 2x6	(2) 2x6	(2) 2x8	(2) 2x8	(2) 2x10	(2) 2x12	(2) 2x12	(3) 2x10	(3) 2x12	(3) 2x12
	Ponderosa Pine Beam	(2) 2x6	(2) 2x6	(2) 2x8	(2) 2x8	(2) 2x10	(2) 2x12	(2) 2x12	(3) 2x12	(3) 2x12	(3) 2x12	Eng Bm
	Corner Footing	7	8	9	9	10	10	11	11	12	13	13
	Intermediate Footing	10	11	12	13	14	15	16	16	17	18	18
9'	Southern Pine Beam	(2) 2x6	(2) 2x6	(2) 2x6	(2) 2x8	(2) 2x10	(2) 2x10	(2) 2x10	(2) 2x12	(3) 2x10	(3) 2x12	(3) 2x12
	Ponderosa Pine Beam	(2) 2x6	(2) 2x6	(2) 2x8	(2) 2x8	(2) 2x10	(2) 2x12	(3) 2x12	(3) 2x12	(3) 2x12	Eng Bm	Eng Bm
	Corner Footing	7	8	9	10	10	11	12	12	13	13	14
	Intermediate Footing	10	12	13	14	15	16	17	17	18	19	20
10'	Southern Pine Beam	(2) 2x6	(2) 2x6	(2) 2x8	(2) 2x8	(2) 2x10	(2) 2x10	(2) 2x12	(3) 2x10	(3) 2x12	(3) 2x12	(3) 2x12
	Ponderosa Pine Beam	(2) 2x6	(2) 2x6	(2) 2x8	(2) 2x10	(2) 2x10	(2) 2x12	(3) 2x12	(3) 2x12	(3) 2x12	Eng Bm	Eng Bm
	Corner Footing	8	9	10	10	11	12	12	13	14	14	15
	Intermediate Footing	11	12	14	15	16	17	17	18	19	20	21
11'	Southern Pine Beam	(2) 2x6	(2) 2x6	(2) 2x6	(2) 2x8	(2) 2x10	(2) 2x12	(2) 2x12	(3) 2x10	(3) 2x12	(3) 2x12	Eng Bm
	Ponderosa Pine Beam	(2) 2x6	(2) 2x6	(2) 2x8	(2) 2x10	(2) 2x10	(2) 2x10	(3) 2x12	(3) 2x12	(3) 2x12	Eng Bm	Eng Bm
	Corner Footing	8	9	10	11	12	12	13	14	14	15	15
	Intermediate Footing	12	13	14	15	16	17	17	18	19	20	21
12'	Southern Pine Beam	(2) 2x6	(2) 2x6	(2) 2x8	(2) 2x8	(2) 2x10	(2) 2x12	(2) 2x12	(3) 2x10	(3) 2x12	(3) 2x12	Eng Bm
	Ponderosa Pine Beam	(2) 2x6	(2) 2x6	(2) 2x8	(2) 2x10	(2) 2x12	(3) 2x12	(3) 2x12	(3) 2x12	Eng Bm	Eng Bm	Eng Bm
	Corner Footing	9	10	10	11	12	13	14	14	15	15	16
	Intermediate Footing	12	14	15	16	17	18	19	20	21	22	23
13'	Southern Pine Beam	(2) 2x6	(2) 2x6	(2) 2x8	(2) 2x10	(2) 2x10	(2) 2x12	(3) 2x10	(3) 2x12	(3) 2x12	Eng Bm	Eng Bm
	Ponderosa Pine Beam	(2) 2x6	(2) 2x8	(2) 2x8	(2) 2x10	(2) 2x12	(3) 2x12	(3) 2x12	(3) 2x12	Eng Bm	Eng Bm	Eng Bm
	Corner Footing	9	10	11	12	13	13	14	15	15	16	17
	Intermediate Footing	13	14	15	17	18	19	20	21	22	23	24
14'	Southern Pine Beam	(2) 2x6	(2) 2x6	(2) 2x8	(2) 2x10	(2) 2x10	(2) 2x12	(3) 2x12	(3) 2x12	(3) 2x12	Eng Bm	Eng Bm
	Ponderosa Pine Beam	(2) 2x6	(2) 2x8	(2) 2x10	(2) 2x10	(2) 2x12	(3) 2x12	(3) 2x12	(3) 2x12	Eng Bm	Eng Bm	Eng Bm
	Corner Footing	9	10	11	12	13	14	15	15	16	17	17
	Intermediate Footing	13	15	16	17	18	20	21	22	23	24	24
15'	Southern Pine Beam	(2) 2x6	(2) 2x6	(2) 2x8	(2) 2x10	(2) 2x10	(2) 2x12	(3) 2x12	(3) 2x12	(3) 2x12	Eng Bm	Eng Bm
	Ponderosa Pine Beam	(2) 2x6	(2) 2x8	(2) 2x10	(2) 2x12	(3) 2x12	(3) 2x13	(3) 2x12	Eng Bm	Eng Bm	Eng Bm	Eng Bm
	Corner Footing	10	11	12	13	14	14	15	16	17	17	18
	Intermediate Footing	14	15	17	18	19	20	21	22	23	24	25
16'	Southern Pine Beam	(2) 2x6	(2) 2x6	(2) 2x8	(2) 2x10	(2) 2x12	(2) 2x12	(3) 2x12	(3) 2x12	Eng Bm	Eng Bm	Eng Bm
	Ponderosa Pine Beam	(2) 2x6	(2) 2x8	(2) 2x10	(2) 2x12	(2) 2x12	(3) 2x12	(3) 2x12	Eng Bm	Eng Bm	Eng Bm	Eng Bm
	Corner Footing	10	11	12	13	14	15	16	16	17	18	18
	Intermediate Footing	14	16	17	18	20	21	22	23	24	25	26

Eng Bm: An engineered beam (e.g. LVL, Microlam, etc.) is required for this joist length and post spacing. This beam and footing design only encompass open decks. No roof loads or additional loads have been considered.

# CHECKLIST FOR DECK PLANS

(This information is to be provided on your plan.) Please Verify!

## Site Plan

- Street address and/or legal description shown
- Q**watonna **P**ublic **U**tilities sign off form
- Size/location of existing buildings, easements and buffers
- All lot dimensions and pin locations shown
- Location and size of proposed deck shown
- Distance from all lot lines to proposed deck
- Locations of existing windows/doors (glass) and window wells if applicable [Tempered glass may be required at landings, walking surfaces, top or bottom tread and next to stairs.]

## Construction Plans

- 2 complete set of plans submitted
- All measurements, distances, sizes and lumber dimensions have been noted on plan
- Plan neat and legible
- Is deck connected to a cantilever? If so indicate what type of floor system the cantilever is framed with.

## Elevation (This could be illustrated on section drawings see page 16)

- Show side and/or front view of deck in relation to grade and dwelling
- Include railing height and design

## Framing Plan {fill in blanks on page 16}

- Floor joist size and spacing including species and grade
- Orientation of floor joists
- Cantilever of joists beyond beam (max. 2 feet)
- Bearing points for all joists
- Size and location of all beams including species and grade
- Cantilever of beams beyond post (max. 1 ft)
- Size and location of ledger board including species and grade
- Size and location of all columns/post
- Location of stairs
- Changes in elevation of deck floors or landings
- Unusual framing issues such as cantilevers of the dwelling floor

## Footings (This information may be included on section or framing plans see page 16)

- Footing depth and design

Footing width at base consistent with load for each footing location.

## Section(s)

- Cross section or top view(s) from bottom of footing to top of guard to show railing details; floor framing orientation; joist/beam orientation and bearing; column locations; connections; footing design, size, and depth; and height of deck floor above grade.

## Details

- Flashing at the ledger
  - Joist bearing/hangers
  - Ledger connection (Caution for dwelling floor cantilevers)
  - Fasteners/connectors consistent with lumber and decking used
  - Column/beam connection
  - Column/footing connection
  - Type of decking and orientation (Caution for 5/4 or composite decking for spans more than 16" o.c. or installed diagonally)
  - Provide manufacture product type on decking material other than wood (Consult with Bldg Inspections prior to purchase) ([www.ambo.com](http://www.ambo.com)) (review reports for approval and installation)
  - Provide stair stringer connection detail
- See examples**
- Lateral bracing is required when the deck platform is 6 feet and greater measured from finished grade (see page 9)
  - Width of stairs (36" minimum width)
  - Rise/run w/tolerance shown
  - Number and size of stringers (see page 8)
  - Open riser design (less than 30" above grade)
  - Type and size of tread consistent with stringer spacing (Caution for decking use)
  - Circle handrail detail that will be used
  - Handrail height shown on plan (see page 8)
  - Landing at bottom of stair (grade is acceptable when within rise tolerance)

## Guards {Fill in blanks page 16}

- Guard height and opening dimensions
- Guard design/materials
- Guard attachment

Date: \_\_\_\_\_

Job Address: \_\_\_\_\_



# Single Family Residential Open Deck Plan

**Directions**

1. Fill in the blanks on page 16 with dimensions and material which will be used to build the structure. Please print legibly.
2. Indicate in the check list which items pertain to your deck design on page 14.

**Address:**

**Size of ledger & size and amount of lags**  
 (example: 2x10 ledger with two 3/8" x 5 1/2" lags @ 12")

**Type of decking** \_\_\_\_\_ x \_\_\_\_\_ - \_\_\_\_\_  
 (example: 1 x 4 - decking board or 2 x 6 - Trex)

2 x \_\_\_\_\_ joist, lumber species, Spaced \_\_\_\_\_" apart  
 (example: 2 x 10; syp #2, spaced 16" apart) see page 12

( ) 2 x \_\_\_\_\_ beam lumber species  
 (example: 2 - 2 x 10; syp #2, beam see page 13)

**Post span** \_\_\_\_\_  
 (example: 13' - 4" apart)

**Joist Cantilever** \_\_\_\_\_"  
 (example: 24")

**Size of post:** \_\_\_\_\_  
 (example 4 x 6 or 5 x 6 or 6 x 6)

**Height above grade:** \_\_\_\_\_ ft & in  
 (example: 5' 6" from grade to deck)

**Beam connection**  
 Type A   
 Type B  See Page 6  
 Type C  Page 6

**Check one box**

**Type of footing**  
 Type A   
 Type B  See page 3  
 Type C  page 3

**Width of footing at base:** \_\_\_\_\_  
 (example: corners 11" & Intermediates 16") see page 13

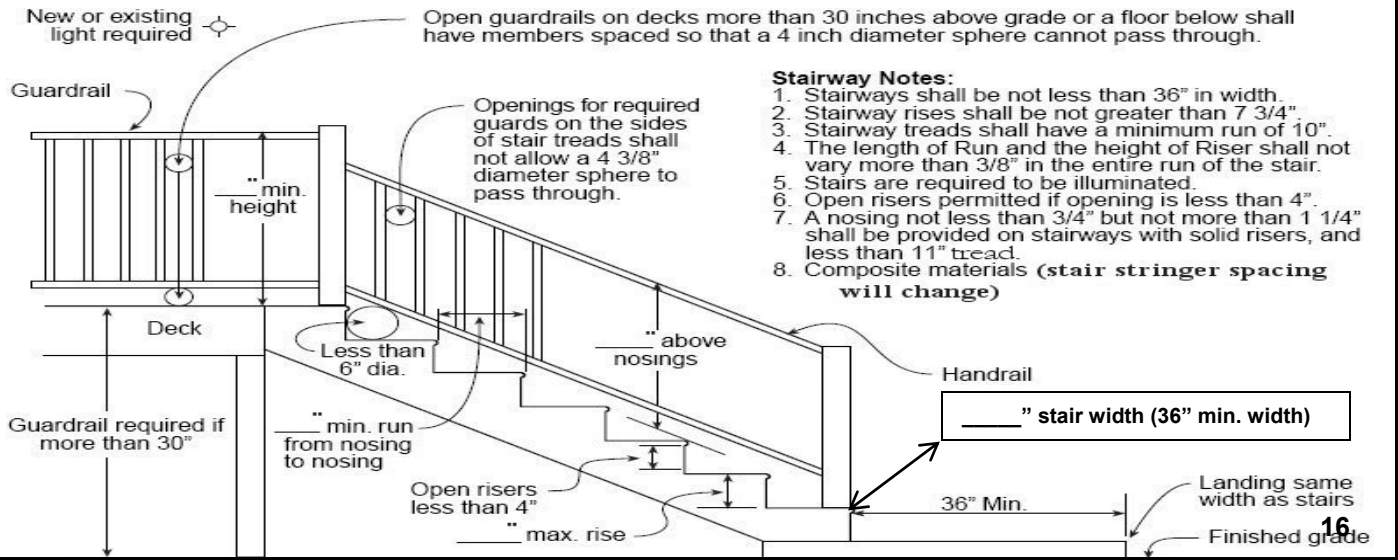
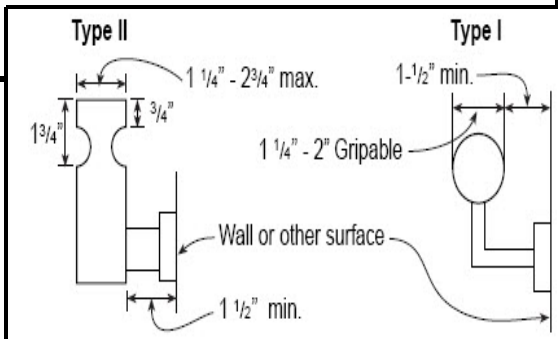
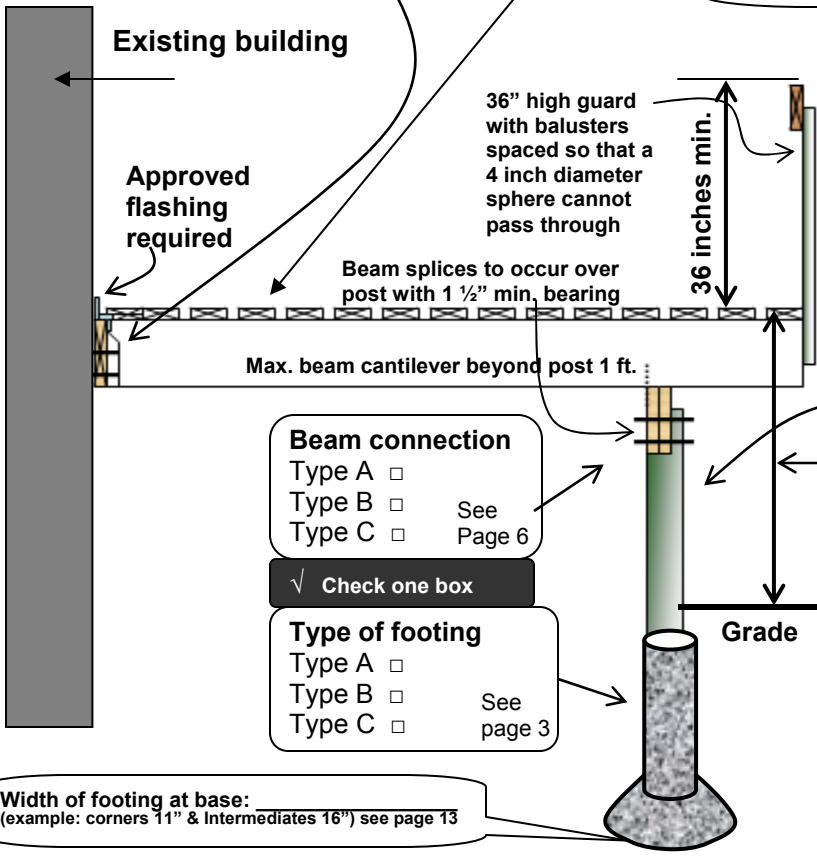

- Stairway Notes:**
1. Stairways shall be not less than 36" in width.
  2. Stairway rises shall be not greater than 7 3/4".
  3. Stairway treads shall have a minimum run of 10".
  4. The length of Run and the height of Riser shall not vary more than 3/8" in the entire run of the stair.
  5. Stairs are required to be illuminated.
  6. Open risers permitted if opening is less than 4".
  7. A nosing not less than 3/4" but not more than 1 1/4" shall be provided on stairways with solid risers, and less than 1 1/2" tread.
  8. Composite materials (stair stringer spacing will change)